



**MODELS**  
**BL 100 & S100**

---

**THIS MANUAL CONTAINS:**

- User's instructions
- Cooking guide
- Installation instructions
- Servicing instructions

**TO THE OWNER OF THE COOKER**

Retain this owner's manual for future reference.

**TO THE INSTALLER**

Leave this owner's manual with the cooker.

# Introductions

## Appliance conformity

- The appliance complies with European Directives EEC 89/336, 92/31 and 93/68 relative to electromagnetic compatibility.
- All our appliances are designed and constructed in compliance with European standards EN 60 335-1 and EN 60 335-2-6 and their subsequent amendments, in conformance with the requirements of the European Low Voltage Directive EEC 73/23 and 93/68.
- The oven accessories that can come into contact with food are constructed using materials that conform to European directive EEC 89/109 of 21/12/88.
- The appliances are constructed in compliance with European gas directives EEC 90/396, EEC 93/68 and European standards EN 30-1/EN 30-2.
- The conformity to the standards is proved by symbol CE applied.

The cooker model and its technical data (power, supply voltage, etc.) appear on the data plate affixed to the inner side of the Plate Warming Door. The factory settings are indicated on the label affixed beside the data plate.

THE APPLIANCE IS DESIGNED FOR DOMESTIC COOKING ONLY. USE FOR ANY OTHER PURPOSE COULD INVALIDATE ANY WARRANTY OR LIABILITY

This booklet gives valuable instructions covering the installation, servicing and use of your cooker.

## Important

After using the cooker, it is advisable to:

- Always check that the control knobs are in the "●" position.
- Also close the gas cylinder valve (if LPG is used) or the supply cock (if natural gas is used).
- Periodically inspect the rubber hose. If it shows any signs of wear it must be replaced: never repair the gas hose.

Contact your qualified installer.

## FOR YOUR SAFETY

The installation must be performed by a competent installer, properly qualified as required by local regulations. Any rewiring required of the household electricians in order to install the cooker should only be carried out by a Qualified Electrician. The manufacturer declines all responsibility for any type of damage resulting from failure to observe the regulations, or from negligent installation of the cooker.

For repairs, always call in an authorised Technical Service Centre and insist on the use of original spare parts.

**Caution:** When in use parts of the cooker become very hot

(e.g. the burners) and remain hot for a long period of time. Use of oven gloves is recommended whilst using your cooker. Children should be kept away from the appliance.

- Make sure there is adequate air circulation around the cooker. Poor ventilation reduces the amount of oxygen in the room. If in doubt, consult the installer. In the interest of hygiene and safety, the cooker should always be kept clean.
- Deposits of grease or other foods can catch fire. Carefully supervise the cooking of oils or fat.
- When you first use your cooker it may give off a slight odour but this will stop after a little use.
- This product has been designed for domestic cooking only and should not be used for other purposes (such as heating a room).
- Avoid installing the cooker close to flammable materials (e.g. curtains, drapes, etc...)
- Operate the cooker with the type of gas specified on the adhesive label placed in the inner side of the Plate Warming Door.
- Before cleaning or servicing the appliance, disconnect it from the electricity supply by unplugging it or by using the main circuit breaker.

**Please note:** The connection hose and the stability chain are part of the installation NOT part of the cooker. They should be provided by your installer and are available at most builders merchants. Notes concerning the hose & the stability chain can be found on pages 20 & 22.

# Contents

CHARACTERISTICS .....	p. 5
INSTRUCTION FOR USE.....	p. 6
TIMER FUNCTION .....	p. 11
COOKING GUIDE.....	p. 13
COOKER CLEANING.....	p. 13
COOKER SERVICING.....	p. 14
TECHNICAL NOTICE FOR INSTALLER .....	p. 17
GENERAL SAFETY INSTRUCTIONS & TROUBLESHOOTING.....	p. 21
ADDITIONAL NOTES FOR ASSEMBLING THE SAFETY CHAIN.....	p. 22
YOUR GUARANTEE .....	p. 23

# Characteristics of the models

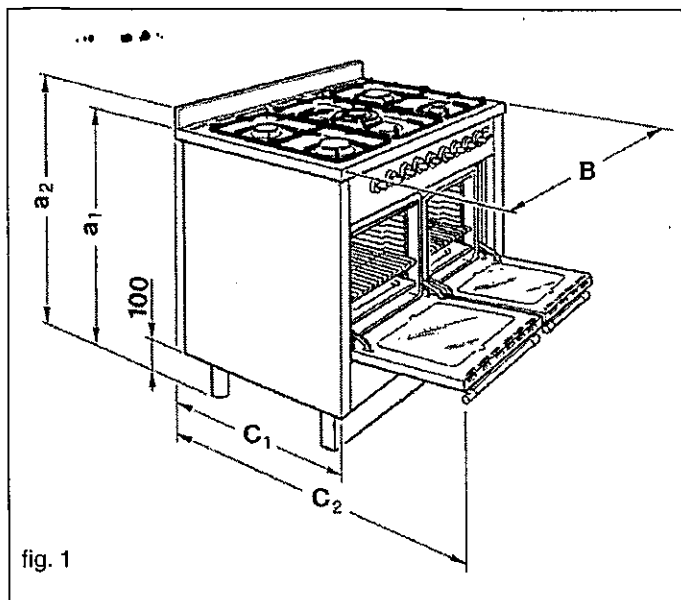

## DIMENSIONS OF THE COOKERS

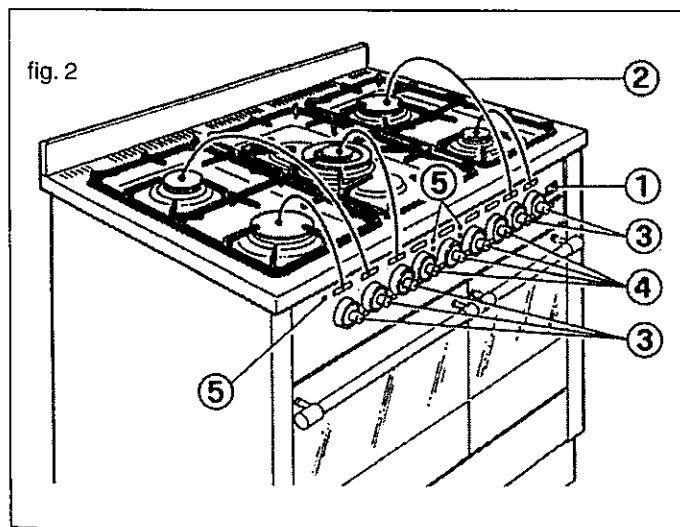

COOKER DIMENSIONS AND CHARACTERISTICS		TWIN 100x60
Height of top	a1=	90±1 cm
Depth	C1=	60 cm
Width	B=	100 cm
Height to top of splashback	a2=	96±1 cm
Depth with over door open	C2=	94 cm
Working capacity		left 57 right 33,5
Class		
Combined and electric cooker type		Y
Ec type examination certificate n.	CE	49 BL 3157 49 BL 3155
Ec type examination		2017 1017
Burners are adaptable for Butane - Propane Natural Gas Category II 2H3+		
Operating voltage		230 - 240 V 50Hz

## DESCRIPTION: CONTROL PANEL



- 1) Digital programmer or analogue clock or timer knob 
- 2) Position of control knobs and their corresponding burners
- 3) Control knobs for the gas burners of the electric hot plates 
- 4) Thermostat knob, electric oven/grill control knob 
- 5) Warning lights

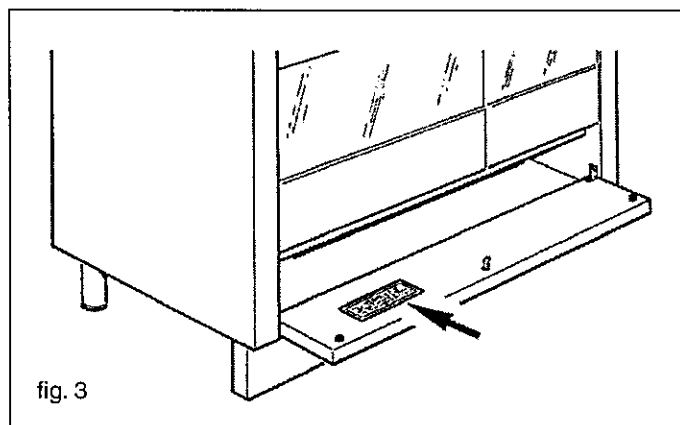

## DATA PLATE

Before connecting the electricity and gas supplies, carefully read the technical data plate affixed to the inner side of the Plate Warming Door (fig. 3). This will indicate the series, number and model of the cooker.

# Instruction for use

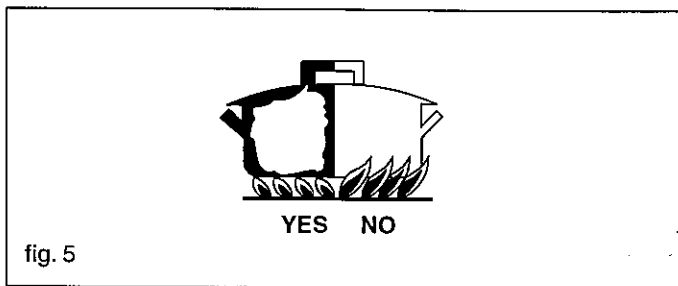
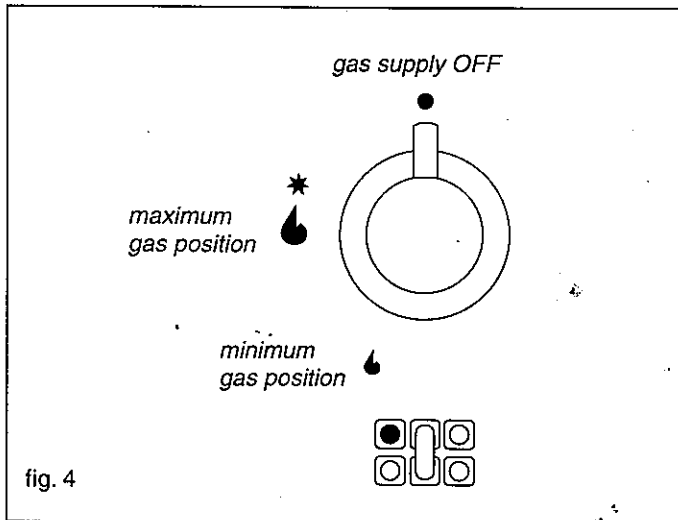

## USING THE BURNERS

### Automatic electric ignition of burners

To light the burner of the hob selected for cooking, push in the corresponding knob and turn in an anti-clockwise direction to the fully on position (shown in Fig. 4); when pressed fully in, the spark will be generated automatically, igniting the burner.

**IMPORTANT:** Do not operate the spark ignition button for a long time, as this can damage the spark generator.

To shut off the gas supply, turn the knob in a clockwise direction to the position ● (gas supply off).

### Suggestions for conserving energy

Avoid using pans that are too small for the burner, so that the flames don't lick up the sides of the pan. When the contents have boiled, reduce the flame setting to a simmer by turning the knob anticlockwise (fig. 4). To facilitate saving gas, the hob has burners with different diameters and power ratings. Use the appropriate burner for each type of pan, as detailed below:

Rapid burner	R	Pan diameter from cm 24/25
Semi-rapid burner	B	Pan diameter from cm 16/18
Auxiliary burner	A	Pan diameter from cm 12/14
Kwali triple flame burner	BK	Pan diameter from cm 24/25

### Twin model ovens and grills

The standard conformation consists of a multifunction oven on the left and a static oven on the right.

The left oven is equipped with grill with an energy regulator.

The right oven is equipped with a fixed grill (with turnspit).

### Runners

The shelves slot into the runners "A". These runners (see Fig. 6) mean that dishes can be cooked at different heights, 10 for twin model, selecting the best height for the particular dish. To remove the shelves see fig. 6. To remove the shelves from the oven, pull and lift as shown in Fig. 6/A below:

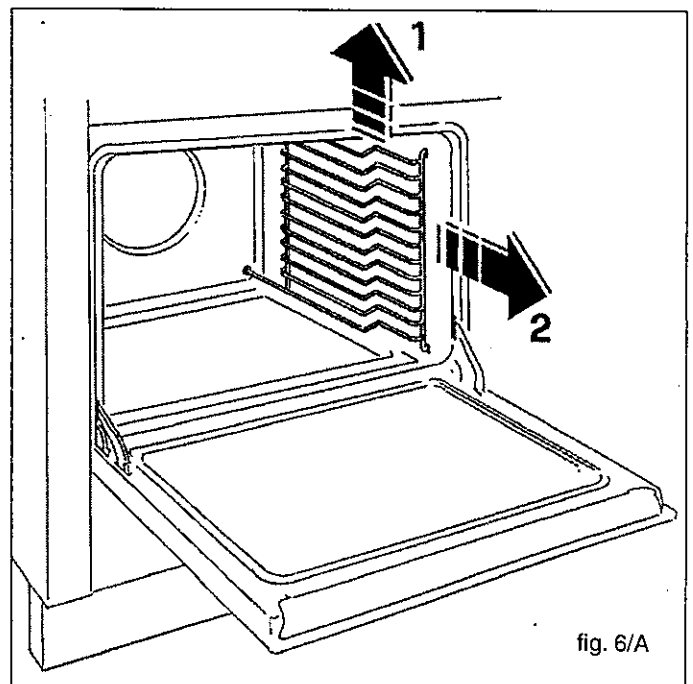
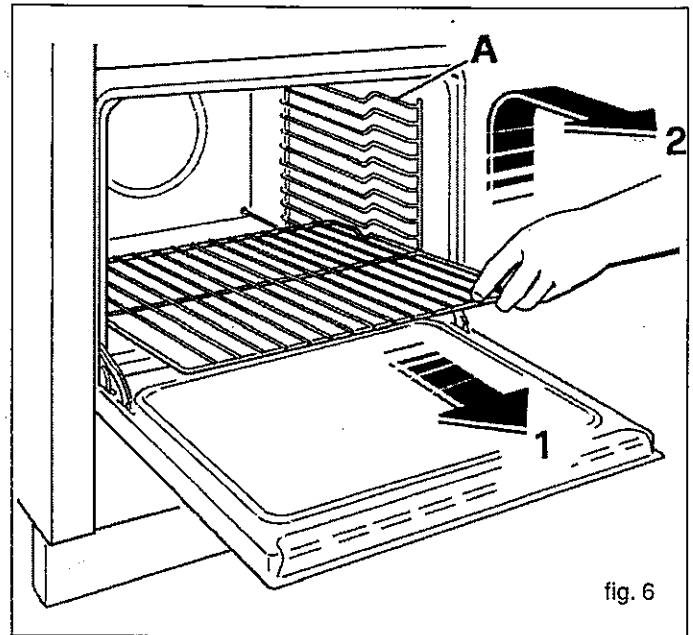

### Tips

Open and close the oven door gently and never leave it ajar when the oven is hot. This could cause damage to the control knobs.

### Cooling fan

Your cooker is fitted with a fan to cool the control panel, the oven doors and the oven door handles. It switches on automatically when the temperature reaches a certain level. The green light on the control panel shows that the fan is operating. The fan stops automatically at the end of cooking when the temperature of the appliance has dropped to a sufficiently safe level.

### The 5 Indicator lights:

- **Green light:** indicates operation of a fan under the hob to cool the oven doors, front panel and exposed parts.
- **Red lights:** there are two. The left-hand light indicates that an electric element in the left oven is on, and the right-hand light operation of an electric element in the right oven.
- **Yellow lights:** there are two. The left-hand light indicates that the left oven or grill is in operation, the right-hand light operation of the right oven or grill.

The lights go out when the corresponding oven reaches the set temperature.

During cooking the light will continue to switch on and off, reflecting the controlling action of the thermostat.

### STATIC ELECTRIC OVEN (right oven)

The electric oven is heated by a bottom element under the oven bottom plate, a top element on the top of the oven and a third element in the top of the oven in the grill position. The thermostat switches the elements on and off to maintain the set temperature in the oven.

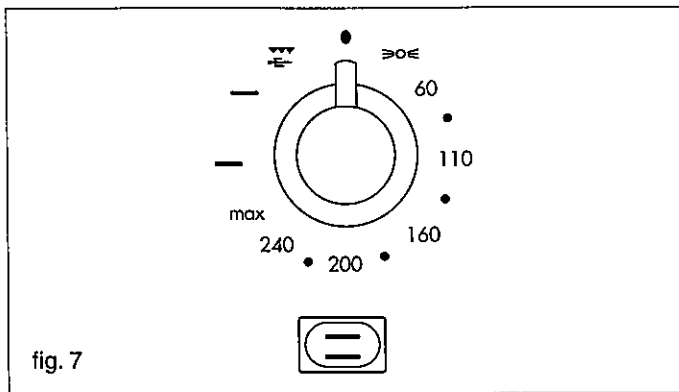

- As the oven knob marked with the symbol is turned clockwise, it encounters the following symbols (Fig. 7).

- ● Oven off.
- Oven light on (it remains on in all functions).
- 60-110-160-220-240-max (oven temperature).
- Bottom element on.
- Top element on.
- Grill element on, turnspit on.

The **red light** indicates that one of the electrical components is on.

The **yellow light** indicates that the thermostat is on.

### Using the electric grill

The same knob that controls the electric oven (Fig. 7) also switches on the grill element, when turned all the way to the right. The grill position is marked with the symbol .

### Using the turnspit

The turnspit is operated by turning the oven knob to encounter the symbol together with the grill.

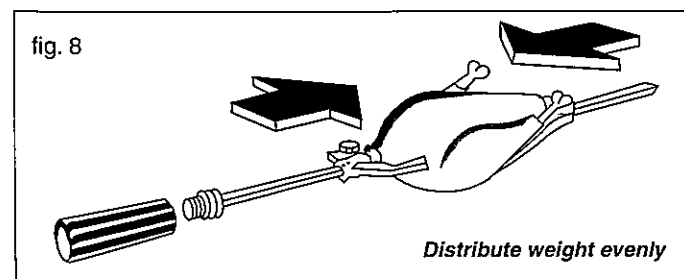

First of all, place the food on the spit, using the two special forks to hold it in place. Take care to distribute the weight evenly, to prevent unnecessary strain on the motor (fig. 8).

Then place the end of the spit in the motor hole, and the opposite end on its special support. Unscrew and remove the plastic handle and turn on the grill.

**Note:** When using the electric grill, keep the oven door closed.

### MULTIFUNCTION OVEN (left oven)

- Allows different types of food to be cooked on more than one shelf.
- Also allows natural convection cooking.
- 8 different cooking functions can be activated.
- Controlled by two or three knobs:
- When knob (1) (Fig. 9) is turned a selector activates the cooking functions identified by the symbols:

- ● Oven off.
- Oven light on (it remains on in all functions).
- 1 top and bottom elements on (static cooking).
- 2 grill element on (grilling).
- 3 fan on without heat (food thawing).
- 4 fan and back element on (fan oven).
- 5 fan and grill element on (fan grilling).
- 6 fan, back element and top element on (delicate cooking at constant temperature).
- 7 fan and top and bottom elements on (fan assisted cooking).
- 8 fan and back and grill elements on (rapid grilling).

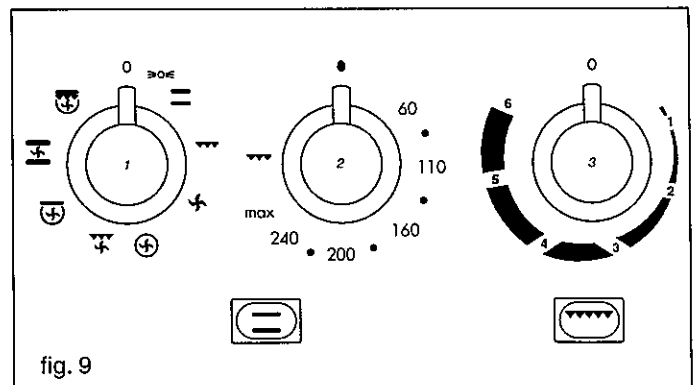

Knob (2) controls the temperature setting.

Knob (3) controls the energy regulation of the grill.

The **red light** indicates that one of the electrical components is on.

The **yellow light** indicates that the thermostat is on.

When using the grill, keep the oven door closed.

### Hints for cooking in a multifunction oven.

(Page 13 cooking guide).

The multifunction oven works when the clock/programmer is set in "manual" or in any programming position.

## Setting 1 - conventional cooking (static oven) (fig. 10 - 10/A)

- Turn knob (1) symbol  .
- Knob (3) (grill energy regulator) to zero
- The heating elements are in operation.
- The red light confirms they are in operation.
- Turn the thermostat knob (2) to the chosen temperature.
- The yellow light comes on.
- Wait for the yellow light to go out before placing the foods in the oven.
- This cooking mode is suitable for biscuits, cakes, bread and roasts.

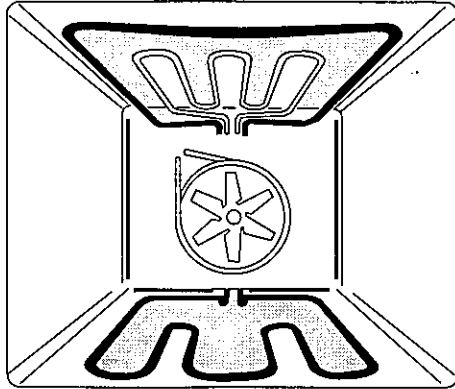

fig. 10

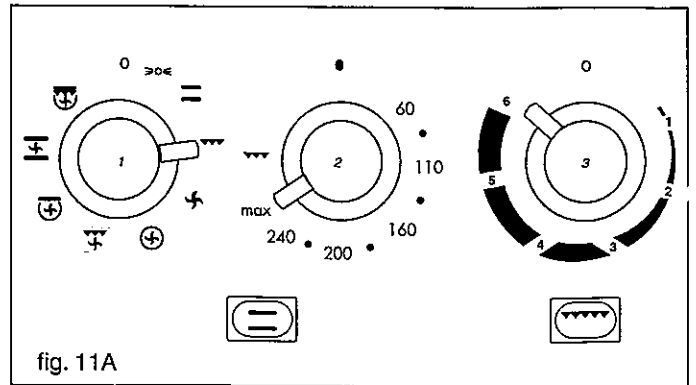



fig. 11A

## Setting 3 - thawing frozen foods (forced ventilation) (fig. 12 - 12/A)

- Turn knob (1) to symbol  .
- Knob (3) to zero
- Only the fan is switched on to circulate air at room temperature.
- The red light indicates it is in operation.
- Turn the thermostat knob (2) to zero.
- This function is suitable for thawing frozen foods.
- Thawing times depend on the quantity of food to be thawed.

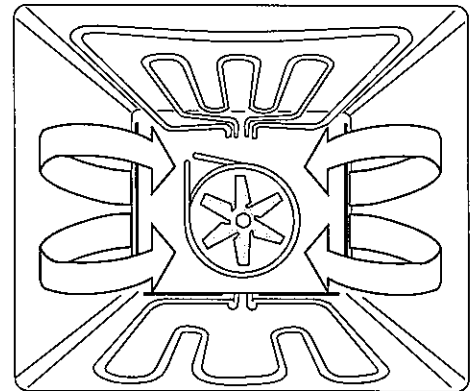

fig. 12

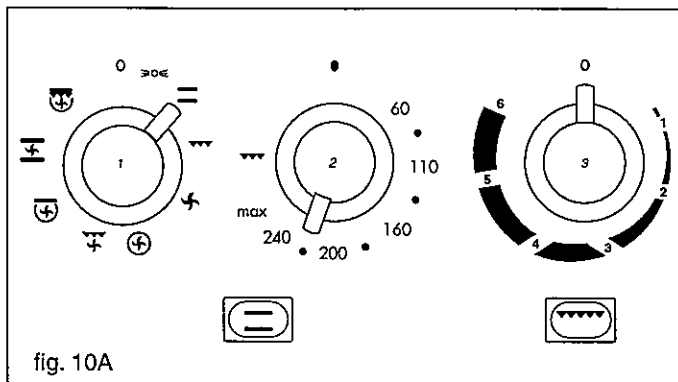



fig. 10A

## Setting 2 - grilling (fig. 11-11/A)

- Turn knob (1) to symbol  .
- Turn knob (3) to 6.
- The grill element is in operation.
- The red light confirms it is in operation.
- Turn the thermostat knob (2) to max.
- The yellow light comes on.
- This cooking mode is suitable for grilling meat, fish and vegetables. It can also be used for grilling bread and bacon. Arrange the foods on the grill grid and place it on the chosen runners.
- The oven door must be kept closed during grilling.
- Turning the knob N°3, you can select a gradual variation of the grill cooking temperature (main oven only).

**Note: When using the grill keep the oven door closed.**

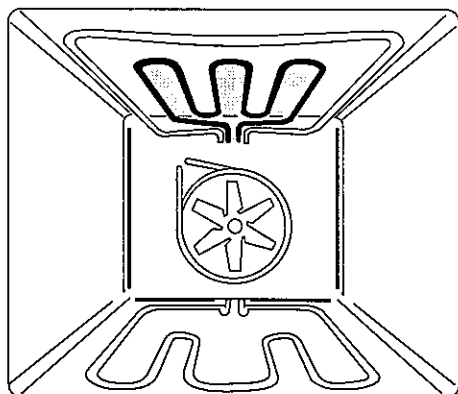

fig. 11

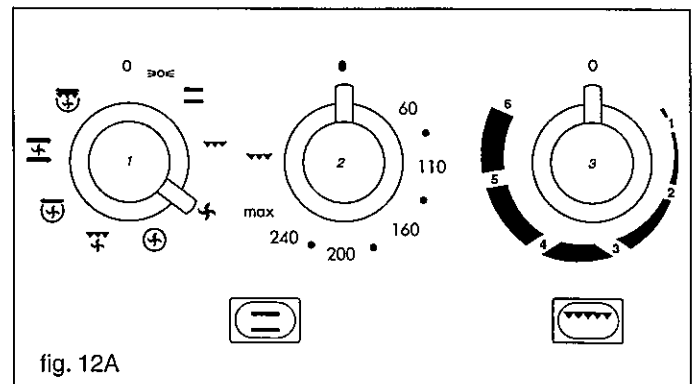



fig. 12A

### Setting 4 - hot air cooking (fan oven) (fig. 13 - 13/A)

- Turn knob (1) to symbol 
- Knob (3) to zero
- The fan and the circular element on the back of the oven are switched on.
- The red light indicates they are in operation.
- Turn the thermostat knob (2) to the chosen temperature.
- The yellow light comes on and will switch off when the set temperature is reached.
- Wait for the yellow light to go out before placing the foods in the oven.
- The heat is spread evenly through the inside of the oven.
- Different types of food can be cooked on more than one shelf.
- This cooking mode is especially suitable for cakes, meat and fish.
- When more than one shelf is used, the cooking times indicated must be increased by approximately 10/15 min.

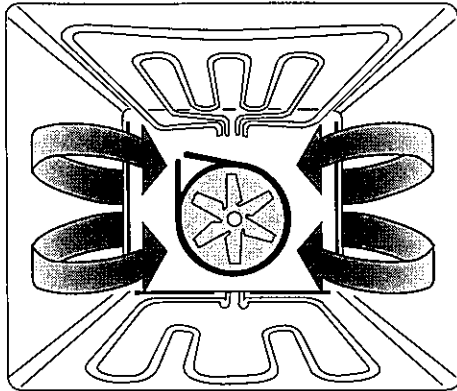

fig. 13

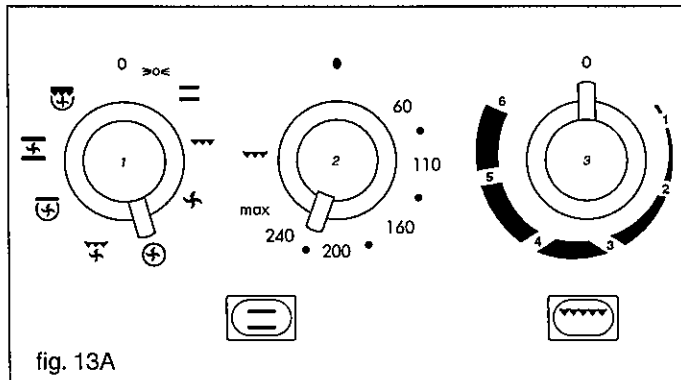

fig. 13A

### Setting 5 - fan grilling (gentle grilling) (fig. 14 - 14/A)

- Turn knob (1) to symbol 
- Turn knob (3) to 6.
- The grill element and the fan on the back of the oven are operating.
- The red light confirms they are in operation.
- Turn the thermostat knob (2) to the chosen temperature.
- The yellow light comes on and will go out when the chosen temperature is reached.
- Arrange the foods on the grill grid and place it so that the foods are about 5 cm below the element.
- Place the tray on the appropriate runners.
- To prevent smoking, pour a little water into the tray and keep the level topped up during cooking.
- The oven door must be kept closed.
- This cooking mode is an alternative to the turnspit; the fan comes on and distributes the heat radiated by the grill.
- It is especially suitable for meat, roasts and poultry.
- Turning the knob N° 3, you can select a gradual variation of the grill cooking temperature.

fig. 14

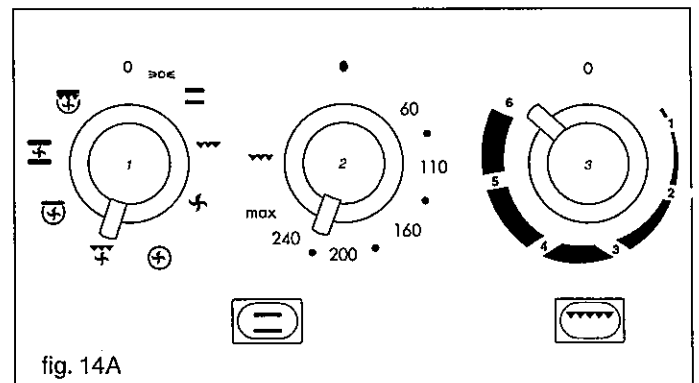
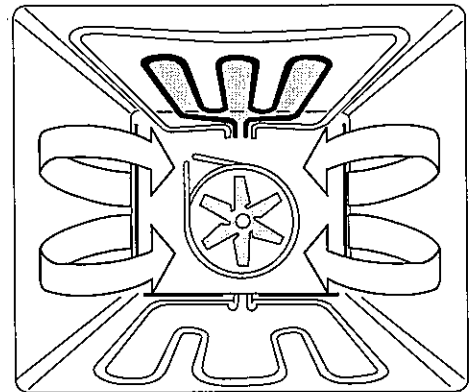



fig. 14A

## Setting 6 - delicate cooking (constant temperature) (fig. 15 - 15/A)

- Turn knob (1) to symbol 
- Turn knob (3) to Zero.
- The top electric element, the back element and the fan on the back of the oven are operating.
- The red light confirms they are in operation.
- Turn the thermostat knob (2) to the chosen temperature.
- The yellow light comes on and will go out when the chosen temperature is reached.
- This cooking mode is suitable for cakes in general and for warming serving dishes.

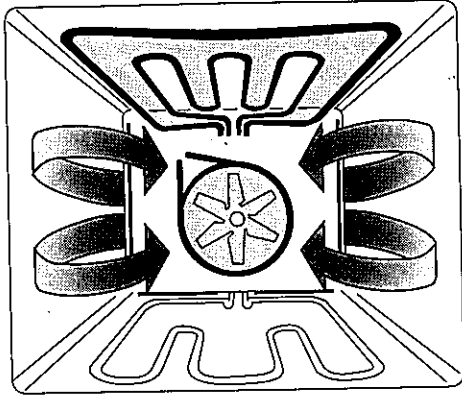

fig. 15

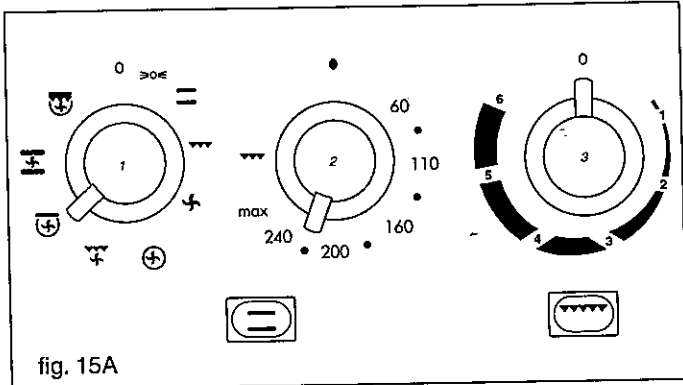



fig. 15A

## Setting 7- conventional fan cooking (fan assisted oven) (fig. 16 - 16/A)

- Turn knob (1) to symbol 
- Turn knob (3) to Zero.
- The top and bottom electric elements and the fan on the back of the oven are operating.
- The red light confirms they are in operation.
- Turn the thermostat knob (2) to the chosen temperature.
- The yellow light comes on and will go out when the chosen temperature is reached.
- Wait for the yellow light to go out before placing the foods in the oven.
- This cooking mode is especially suitable for cooking large amounts of food, such as roasts, turkey, etc.

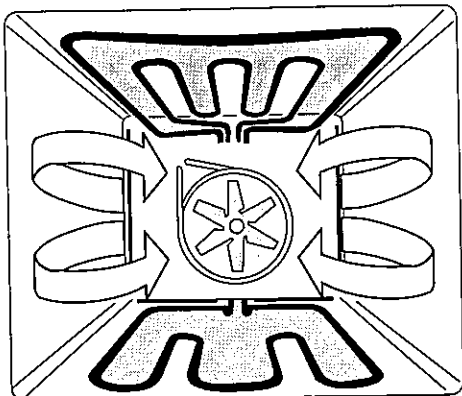

fig. 16

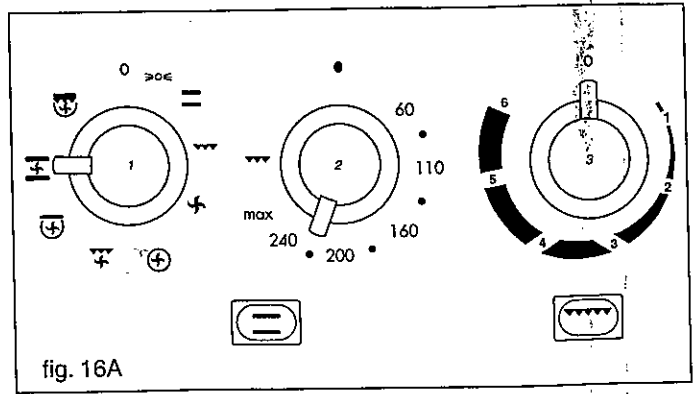



fig. 16A

## Setting 8 - rapid grilling (fig. 17 - 17/A)

- Turn knob (1) to symbol 
- Turn knob (3) to 6.
- The top electric element, the grill, the circular element at the back of the oven and the fan are operating.
- The red light confirms they are in operation.
- Turn the thermostat knob (2) to the chosen temperature.
- The yellow light comes on and will go out when the chosen temperature is reached.
- Wait for the yellow light to go out before placing the foods in the oven.
- This function is an alternative to the turnspit for cooking large amounts of food such as lamb, turkey, chops, sausages, etc.
- Turning the knob N° 3, you can select a gradual variation of the grill cooking temperature.

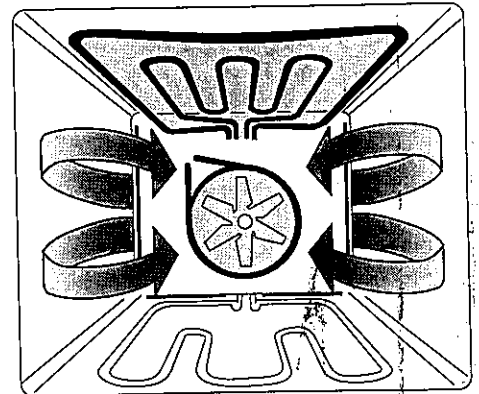

fig. 17

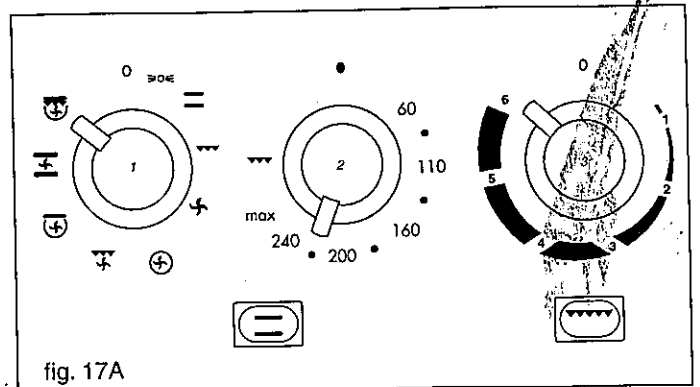
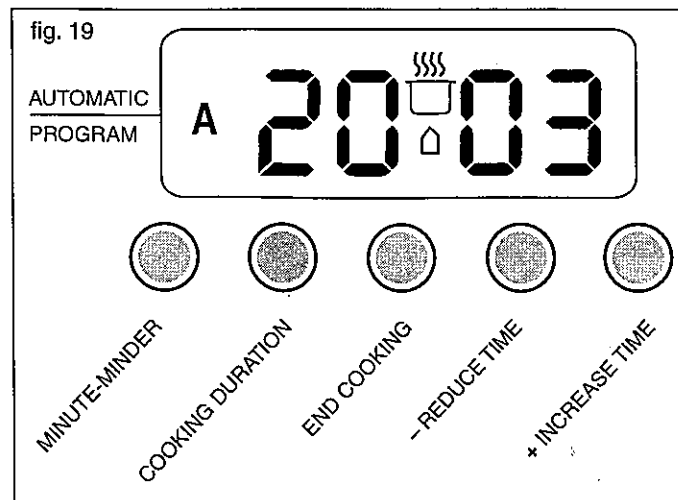

fig. 17A

# Timer function

## Electronic cooker programmer



### FUNCTIONS

Cooking duration, cooking end time, time of day, minute minder "-", "+", manual selection.

### DISPLAYS

4-digit, 7-segment display for time of day and switching times.  
"Dialogue" display to identify condition of timer:

Duration and manual mode = Cookpot symbol  
Automatic programme = A  
Minute minder = Bellsymbol

### SETTING

Select a function by pressing the function button and set the required time with the +/- buttons.

### +/- BUTTONS

Pressing the "+" button increases the time set, pressing "-" decreases it. The count-up or count-down speed increases the longer the button is held in the appropriate position.

### SETTING TIME OF DAY

Set time of day by pressing the COOKING DURATION and END TIME buttons together and adjust with +/- buttons.

### MANUAL COOKING

To clear any programmes and use the oven normally press the COOKING DURATION and END TIME buttons together.

### SEMI-AUTOMATIC COOKING

To set the oven to stop cooking automatically press the COOKING DURATION or the END TIME button and use +/- buttons to set how long you wish cooking to continue. Turn the appropriate temperature and function control knobs to the desired positions. Cooking will start immediately. When the set time has elapsed the oven will stop cooking, the alarm will sound and the symbol "A" will blink.

Press any button to turn the alarm off. Turn the dials to the Off positions.

### FULLY AUTOMATIC COOKING

To set the oven to turn on and off at a future time first press the COOKING DURATION button and adjust how long you wish the oven to cook with the +/- buttons. Then set the time you wish cooking to END by pressing the END TIME button and adjusting the time with the +/- buttons. Turn the Temperature and Function knobs to the desired positions. The symbol "A" will appear on the screen. When the oven turns on a cooking pot symbol will also appear on the screen. When cooking is finished the oven will turn off, the cooking pot symbol will disappear and an alarm will sound.

### MINUTE MINDER

This works as a simple alarm. Press the MINUTE MINDER button and adjust the number of minutes with the +/- buttons. When the set time has elapsed the alarm sounds.

### AUDIBLE SIGNAL

The alarm will sound for a maximum of 7 minutes.

To turn the sound off press any function button.

You can choose from three different sounds by pressing the - button on its own.

### PROGRAMME START AND VERIFICATION

Once a programme has been started you can check how long it has to run by pressing the appropriate function button.

### SETTING ERROR IDENTIFICATION

The setting is incorrect if time of day is in between the calculated cooking start and end times. If an error has been made, this will be indicated by the alarm and by the symbol "A" flashing.

### CANCELLING A PROGRAMME

A programme can be cancelled by setting the oven to Manual (press the COOKING DURATION and END TIME buttons together).

## Griddle plate

Before using for the first time: wipe the surface of the griddle plate with oil and heat so that the oil evaporates (repeat after each use). Place the griddle plate on the central burner. Pre-heat for 5 minutes. The control knob can be turned to a lower position.

**Caution:** the Griddle will be very hot when used. If handling ensure adequate protection is used. Young children should be kept away from the appliance.

## Plate Warming compartment

To access the compartment, open the door as shown in fig. 19, pressing the centre of the door. Do not store dusters or other flammable objects in the compartment.

The plate warming compartments are useful storage areas. They get warm during use of the ovens and can be used to warm your plates or dishes.

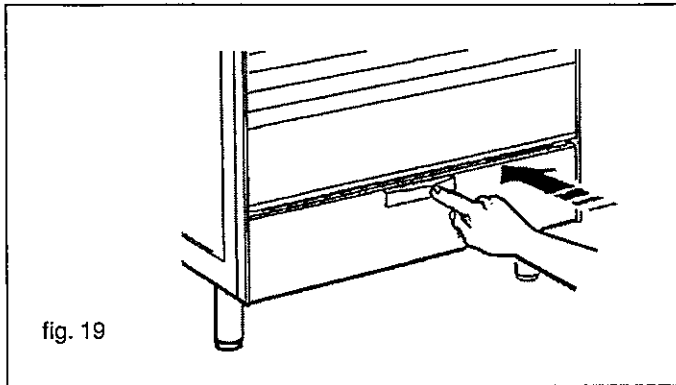

## PANSET USE

### Using a pan set in a right-hand oven

For cooking operations requiring the use of the oven shelf, the tray provided should be placed in the runners beneath the shelf, as shown in fig. 20, in order to collect the drops of fat.

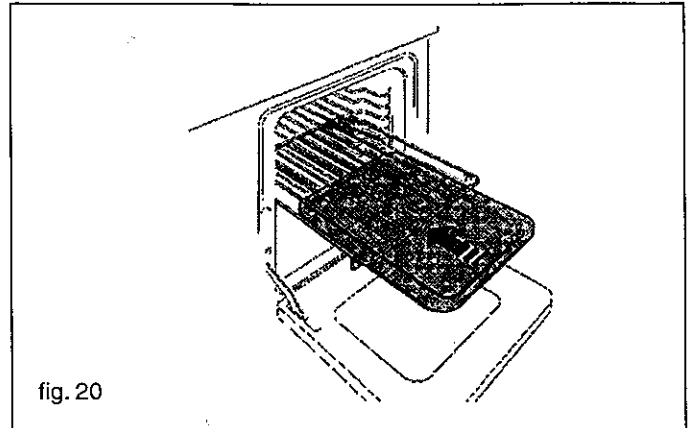

To grill using the PAN SET, the tray can be placed on the shelf with the TRIVET inside the tray (fig. 20/A). Place the shelf on the runners most suitable for the cooking procedure, bearing in mind that the food should be about 5 centimetres (two inches) from the grill element.

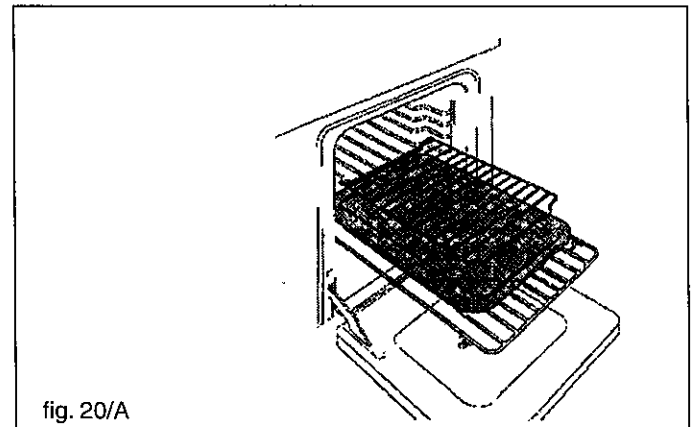

When using the turnspit, it is best to place the shelf on the bottom runners and place the tray on the shelf to collect the drops of fat (fig. 20/B).

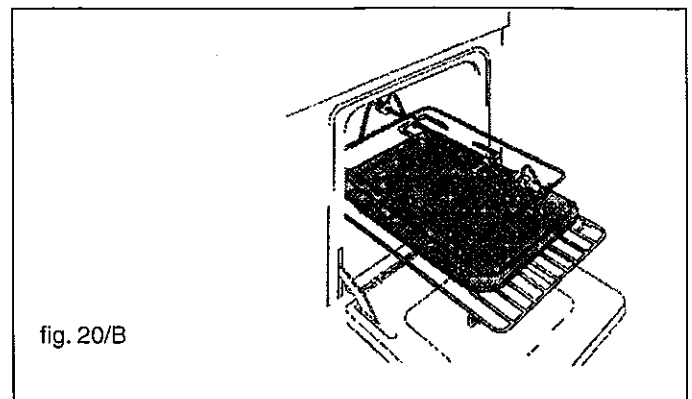

# Cooking guide

## OVEN COOKING CHART

The oven control setting and cooking times given below are intended to be used only as a guide. Individual taste may require the temperature to be altered to provide a preferred result. For best results preheat the oven until the yellow light goes out.

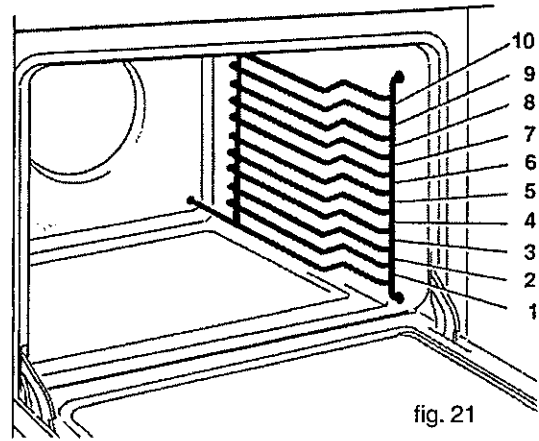

Note: Guide Only

	LEFT OVEN			RIGHT OVEN			SINGLE CAVITY		
	TEMPERATURES °C	POSITION ON RUNNERS	COOKING TIME MINUTES	TEMPERATURES °C	POSITION ON RUNNERS	COOKING TIME MINUTES	TEMPERATURES °C	POSITION ON RUNNERS	COOKING TIME MINUTES
SPONGE CAKES	200	/	40 - 50	180	4°	35	200	/	40 - 50
VICTORIA SANDWICH	200	2° - 7°	25	/	/	/	200	2° - 7°	25
BISCUITS	200	2° - 7°	15	180	2°	15	200	2° - 7°	15
SCONES	240	2° - 7°	15	220	2°	15	240	2° - 7°	15
SMALL CAKES	180	2° - 7°	20 - 25	160	2°	30	180	2° - 7°	20 - 25
MERINGUES	110	2° - 7°	120	85	2°	120	110	2° - 7°	120
BEEF	200	4° - 6°	20 per Kg + 20	180	4° - 6°	25 per Kg + 25	200	4° - 6°	20 per Kg + 20
T-BONE STEAK (GRILLED)	GRILL	7° - 9°	7 + 7	GRILL	7° - 9°	5 + 5	GRILL	7° - 9°	7 + 7
LAMB	200	4° - 6°	35 per Kg + 35	180	4° - 6°	35 per Kg + 35	200	4° - 6°	35 per Kg + 35
PORK	200	4° - 6°	35 per Kg + 35	180	4° - 6°	35 per Kg + 35	200	4° - 6°	35 per Kg + 35
SOUFFLÉ	200	2° - 3°	35 - 40	200	2° - 3°	35 - 40	200	2° - 3°	35 - 40
PIZZA	240	4° - 6°	40	240	4° - 6°	40	240	4° - 6°	40
GRATIN DAUPHINOIS	180	4° - 6°	50 - 70	160	4° - 6°	50 - 70	180	4° - 6°	50 - 70

# Cooker cleaning

Never use detergent, abrasive powder and strong cleaning products that might damage the surfaces. Never use metal pads, steel wool, scourers, knives or similar which scatch surfaces.

### Enamelled, stainless steel and painted surfaces

Wash using a soft moistened soap pad (with neutral soap). Wipe and rinse with cold water. Dry using chamois leather or similar product.

### Enamelled burner caps and pan supports

Allow the burners and pan supports to cool before cleaning. Wash with a sponge and soap. If the openings are blocked, do not use metallic objects to clear them; preferably use a wooden tooth-pick.

### Glass windows

To clean the window in the oven door, use a sponge covered with a small amount of soapy detergent. Rinse with cold water. Repeat for the internal glass.

### Cleaning of self-cleaning catalytic oven

Heat the oven to Max for about 1 hour. Allow to cool and gently wash with a soft moistened pad. Reheated for quarter of an hour maximum temperature for the oven to dry out.

### Griddle plate (optional extra)

Clean the griddle only when cold using a damp sponge and soap. If food remnants are difficult to remove, leave the plate to soak in water, then wash with a sponge. Never use metallic objects such as knives, forks, brushes, etc.

**WARNING:** Avoid pouring water directly on to the plate when it is hot.

		Hot Soapy Water	Dish-washer Safe	Nylon Scourer	Moistened Soap Pad	Aerosols*
Hob	Pan support	●	●	●	●	●
	Burner caps	●	●	●	●	●
	Flame divider	●	●	●		
Hob	Griddle Plate	●	●	●		
	Dish warmer door	●				
	Oven cavities	●		●	●	
Oven cavities	Inside Oven**	●		●	●	
	Oven glass	●		●	●	
	Door stripes	●				
	Door seal	●				
	Drip tray	●	●	●		
	Baking tray	●	●	●		
	Runners	●	●	●		
Other	Grill set	●	●	●		
	Grill grid	●	●	●		
	Side Panels	●				
Other	Knobs	●				
	Handle	●				

\* Aerosols recommended for use on vitreous enamel

\*\* For self-cleaning ovens refer to pag. 13

# Cooker Servicing

## GENERAL GUIDELINES

All servicing operations described in this section must be carried out by qualified personnel only.

Before starting any servicing operations on a cooker, it must be unplugged or switched off at the mains supply. If work is to be carried out on the electrical or gas components underneath the hob (e.g. switches, thermostat taps, etc.) follow the order shown in Fig. 22 below.

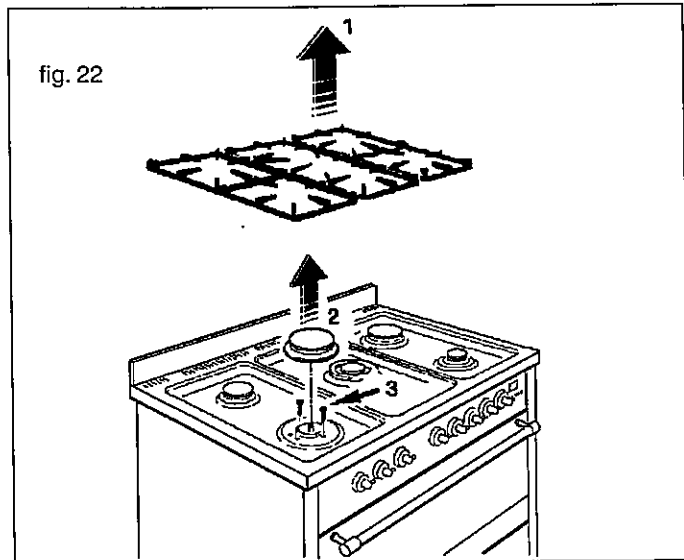

- 1) remove the pan supports.
- 2) remove the burners and unscrew the screws as shown in Fig. 22.
- 3) unscrew the 7 screws on the back of the cooker (Fig. 23). Having completed the above, remove the hob.

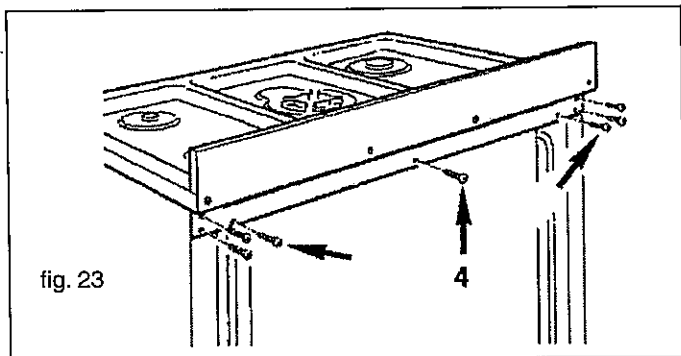

To remove the control panel, follow the instructions in Fig. 24, removing knobs "A" and unscrewing the screws "B".

To replace the hob and control panel, repeat the operation in reverse.

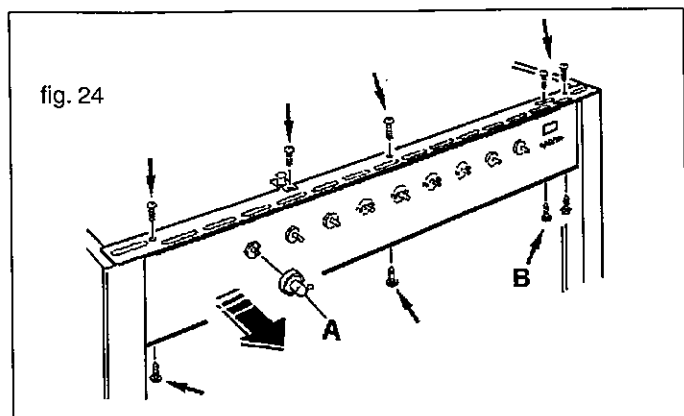

## IMPORTANT:

Check that the hose connecting the cooker to the gas pipe or cylinder is in good condition and replace if damaged with a pipe meeting correct standards, in accordance with B.S. 669.

Respect expiry dates for use.

## REPLACEMENT PARTS

If it becomes necessary to replace certain parts:

Give them the details provided on the DATA PLATE; you will find this on the inside of the Plate Warming Door (see Fig. 3 on page 3).

They will have the parts list and technical documentation relating to our products, and will quickly be able to supply you with any replacement parts and arrange for any necessary repairs to be carried out.

## Replacement of the oven light

This light is located on the ceiling of the oven, and is accessible from the inside of the oven (Fig. 25)

- Unscrew the glass cover
- Remove the light and replace with another with the same specification:
  - Voltage 230V 50Hz
  - Power 25W
- Base E27 - Resistant to high temperatures (300°C).

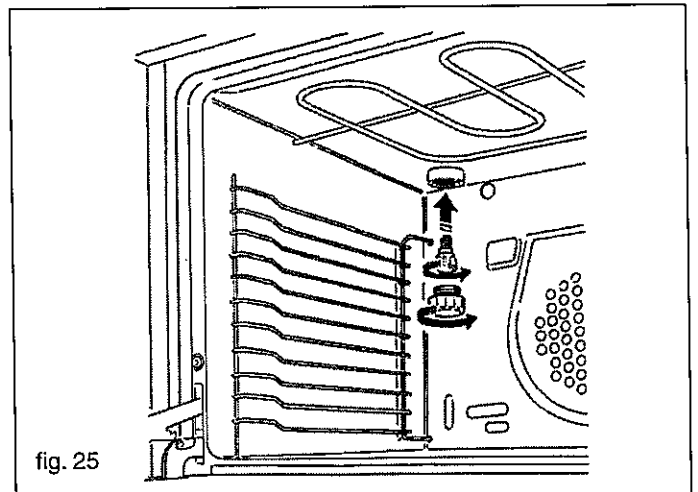

### Replacement of the oven door

- With the door open, insert hook "A" into the moving part of hinge "B"
- Partially close the door and force it upwards to remove stop "C" and sector "B" of the hinge.
- As soon as the hinge is free, pull the door forwards tilting it slightly upwards to release sectors "C" and "B" (Fig. 26).
- To reassemble, repeat the operations in reverse, taking care to insert sectors "C" and "B" into their housing.

### Replacing and cleaning the door glass

With the door dismantled, simply unscrew screws "A" from the oven door lining. (Figs 27 - 27/A).

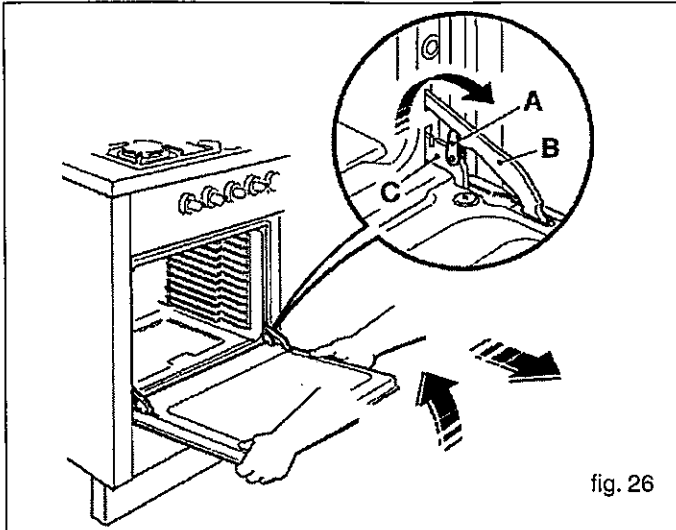

fig. 26

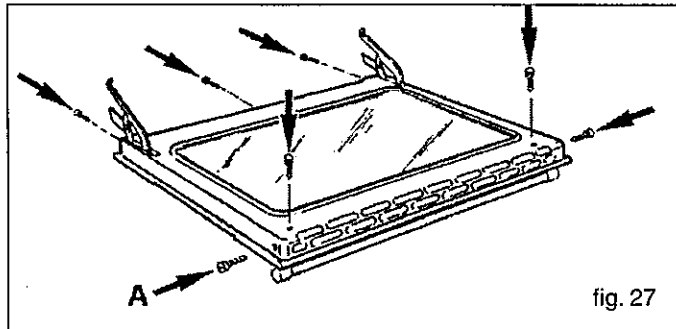

fig. 27

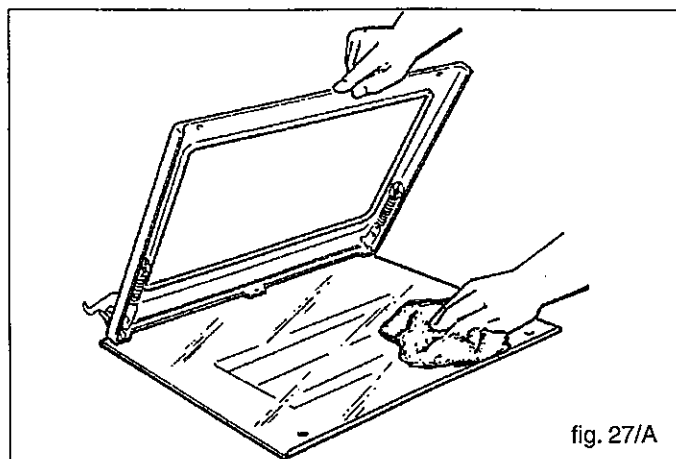

fig. 27/A

### GREASING THE TAPS AND THERMOSTAT

If a tap becomes blocked or hard to turn, it should be re-greased as follows:

- close the gas inlet valve or the tap on the cylinder
- remove the hob following the sequence of instructions in Fig. 22 - 23 - 24
- unscrew the control panel screws and remove it (Fig. 28)
- remove the ignition switch "B" (Fig. 28) if fitted after removing clip "A"
- unscrew the two cap mounting screws (A - Fig. 28)
- remove the cap using pliers
- clean the cap and its seating carefully
- cover the cap with a light layer of grease specially for gas taps, replace it in its seating and turn several times
- remove the cap once more and wipe off any excess grease; check that the hole through which the gas passes is not blocked.

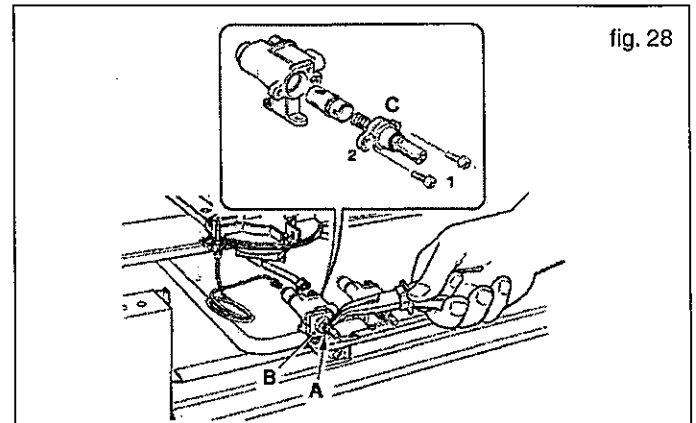

fig. 28

### REPLACEMENT OF THE TAPS

When replacing a tap, follow the instructions below:

- Remove the knobs by pulling
- Remove the hob and the control panel following the sequence of instructions in Fig. 22 - 23 - 24.
- Take the burners apart as shown in Fig. 29.
- Remove the ignition switch "B" (Fig. 29) - if fitted - after removing clip "A"
- Unscrew the lock nuts "C" from the junction ramp between the burner (Fig. 34) and, for cookers fitted with a safety thermocouple, unscrew nuts "D" to remove the taps
- Lift the mounting support and unscrew screws "E" (Fig. 30)
- Partially lift the ramp
- Unscrew screws "F" to remove the tap
- Replace the seal when replacing a tap to ensure a perfect seal between the body and the ramp.

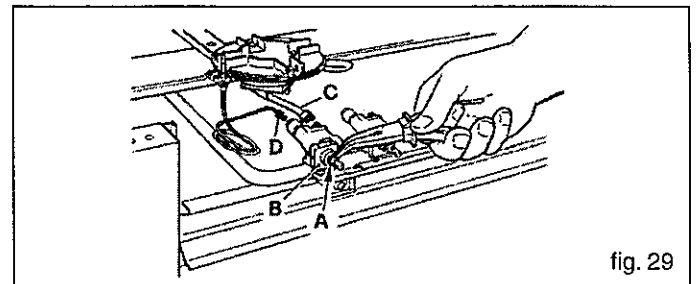

fig. 29

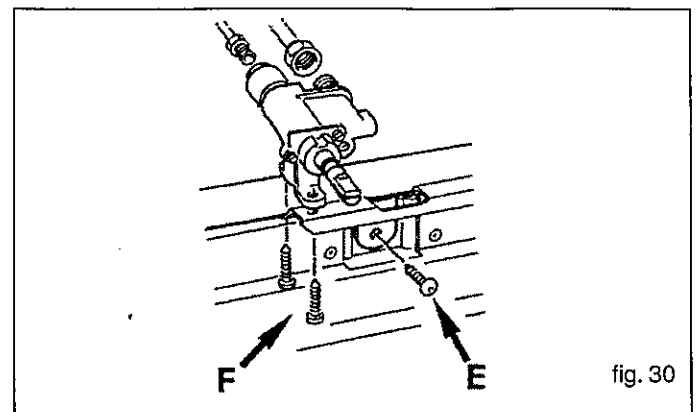

fig. 30

### REPLACEMENT OF THE BURNERS AND SWITCHES

To replace these accessories, remove the hob following the sequence of instructions in Fig. 22 - 23 - 24

To take the burners apart follow the sequence of instructions in Fig. 31-32.

1) unscrew the lock nuts "C" and "D" and screws "E" (Fig. 31)

2) with the burner free turn and unscrew screws "F".

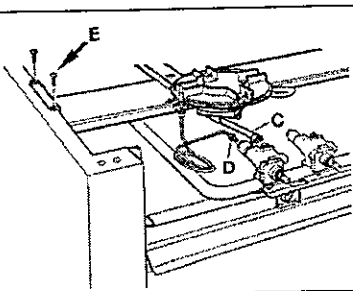

fig. 31

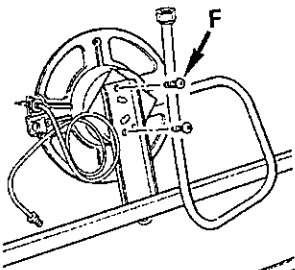

fig. 32

### REPLACEMENT OR FITTING OF POWER SUPPLY CABLE

Follow the advice below: (see Fig. 33)

- Remove the rear panel of the cooker by unscrewing screws "B"
- Connect the power supply cable selecting the type indicated in the table on page 16/17 "ELECTRICAL CONNECTION"
- Replace the rear panel using the same procedure in reverse.

### COMMENTS

The earth conductor must be longer than the active conductors.

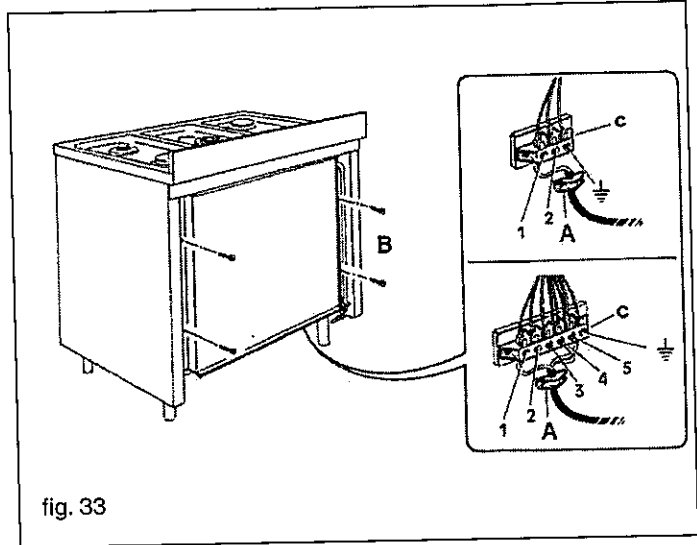

fig. 33

T  
IN  
T  
Ir  
o  
Ir  
1  
2  
3  
4  
5  
6  
7  
/  
/  
t  
/  
t

## LPG GAS ONLY

Do not install this appliance in a room below ground level. This does not preclude installation in rooms which are basements with respect to one side of the building but open to ground level on the opposite side. Failure to install appliances correctly is dangerous and could lead to prosecution.

**WARNING:** It is the responsibility of the installer to ensure that the standards referred to below are strictly adhered to. The manufacturer declines all responsibility deriving from the failure to apply these standards.

## CONNECTION TO THE GAS MAINS

**IMPORTANT:** The installation must be carried out in compliance with local regulations. Install the appliance in a well-ventilated room, check that the gas meter capacity and pipe diameters are sufficient to supply all the connected appliance. Do not forget to install, upstream of the appliance, a gas cock no smaller than 1/2", in a clearly visible and accessible position.

Before connecting the appliance, check the data plate affixed to the inner side of the Plate Warming Door or to the back of the appliance for the type of gas, the working pressure and the capacity.

## NOTE:

- do not forget to fit the seal
  - to allow ease of servicing and cooker mobility a flexible connection (1.25m ideally - to allow more flexibility to move e.t.c).
- The hose should be fitted so that both inlet and outlet connections are vertical so that the hose hangs downwards.

For **Natural Gas** the flexible hose should be accordance with BS 669.

For **LP Gas** it should be capable of 50mBar pressure, 70°C rise and carry a red stripe, band or label.

- Important: once installation is complete, check that all connection seals are tight using a product specifically manufactured for leak detection, never a flame or even washing up liquid as this can cause corrosion.

- check that the gas pressure entering the cooker is as required:

Liquid gas:	butane	G28/30mbar
	propane	G31/37mbar
Methane gas:	natural	G20/20mbar

## ADAPTATION FOR DIFFERENT TYPES OF GAS

To adapt the cooker for a different type of gas than that for which it was designed (see the labels on the inside of the Plate Warming Door), carry out the following operations:

- disconnect the appliance from the mains to avoid any accidental contact.
- replace the burner injectors on the hob:
- adjusting the minimum settings of the hob burners

No adjustment of the burner primary air is required.

Once the gas regulation is completed, replace the data plate inside the plate warming door (Fig. 3) with the correct one supplied with the injector set.

fig. 39

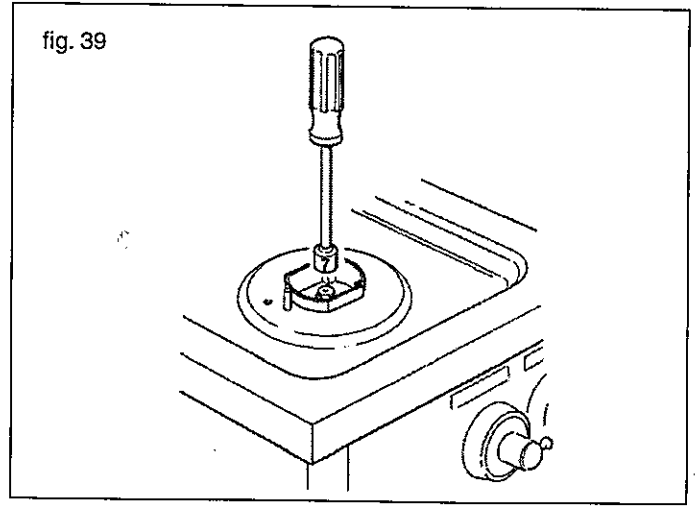

## CHANGING THE INJECTORS FOR THE DIFFERENT TYPES OF GAS

### Hob Burners:

- remove the pan stands, the flame dividers and the burner heads from their mountings;
- select from the pack of injectors, checking the corresponding indication on the injector, the appropriate one for each burner and for the desired type of gas (see the table on page 3);
- using a 7 mm spanner unscrew the injectors fitted (Fig. 39) Replace them with the appropriate injectors and tighten them without excessive force;
- replace the heads and the caps of the burners on the burner cap supports;
- adjust the low settings as indicated in the chapter "Adjusting the low settings" below.

Rapid burner	R	diameter	0.42 mm	yellow
Semi-rapid burner	B	diameter	0.32 mm	blue
Auxiliary burner	A	diameter	0.27 mm	red
Fish burner	P	diameter	0.57 mm	white
Kwali burner	BK	diameter	0.57 mm	white

fig. 40

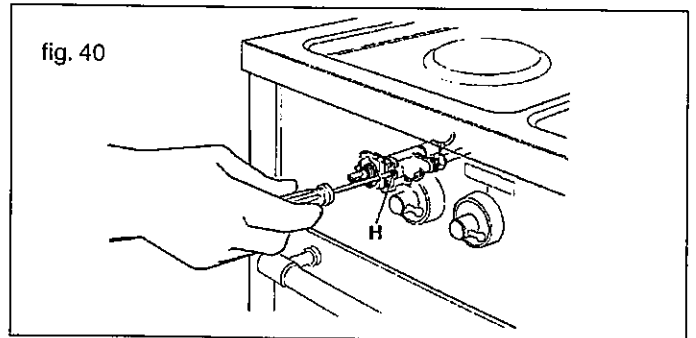

## ADJUSTING THE LOW SETTINGS (REDUCED FLOW)

Adjusting the low settings of the hob burners (Fig. 40)

- light one burner at a time, in the fully on position, remove the knob using a screwdriver, unscrew by approximately three turns minimum screw H located on the right hand side of the stem, turn the tap to the left to the reduced gas flow position and turn screw H until a small regular flame is obtained.

With butane or propane gas the screw will be screwed fully down. These screws are pierced and mounted on the tap according to the type of burner.

## N.B.

Check that when turning the tap rapidly from the fully on position to the minimum position, the burner does not go out. The taps are colour-marked (see table below):

## ELECTRICAL CONNECTION

This appliance must be installed by a qualified electrician to comply with the relevant Institute of Electrical Engineers (I.E.E.) regulations and also the local electricity supply company requirements. Check that the network characteristics (voltage, nominal power, etc.) correspond to those indicated on the small plate mounted on the inside of the oven or Plate Warming Door or on the back of the cooker.

The appliance is designed for installation with connection to a single phase earthed supply, 230V~50Hz.

For connection to the supply a 30/32A double pole switch should be fitted upstream of the appliance with a contact opening distance of at least 3mm at an accessible point.

The appliance should be earthed using particular care by a qualified engineer, who can also check the suitability of the power supply network. When the cooker is installed, check that the power cable is not in contact with metal parts at the back of the cooker. The power supply cable must be located so that it does not reach at any point the temperature of 75°C. Do not use transformers or shunters for connecting the appliance because these could cause false contacts and dangerous overheating.

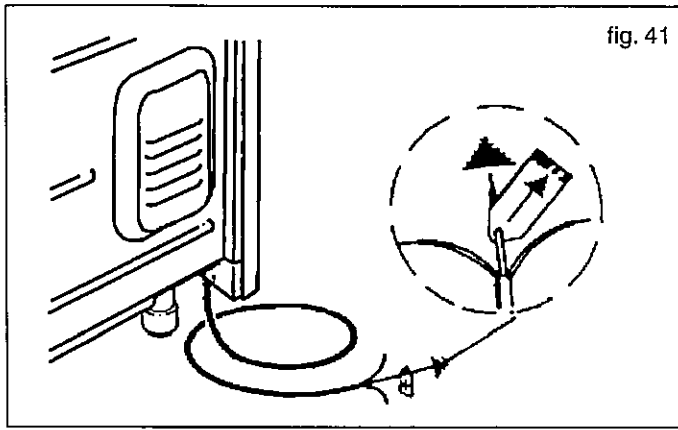

**WARNING:** It is the responsibility of the installer to ensure that the standards referred to below are strictly adhered to. The manufacturer declines all responsibility deriving from the failure to apply these standards. This appliance must be earthed.

## TIPS FOR INSTALLATION

Before proceeding with connection, check that:  
the electrical supply can support the load of the appliance (see characteristics booklet, Fig. 3, page 5);  
the electrical installation is fitted with an effective earth & the double pole switch can be accessed easily with the cooker fitted.

When the cooker has been installed, check that the power cable is not in contact with the metal parts at the back of the cooker, and that it does not at any point reach a temperature of 75°C.

## CURRENT OPERATED EARTH LEAKAGE BREAKERS

Where the installation is protected by a 30 milliamp sensitivity residual current device (RCD), the combined use of your cooker and other domestic appliances may occasionally cause nuisance tripping. In these instances the cooker circuit may need to be protected by fitting 100 mA device. This work should be carried out by a qualified electrician.

## REPLACEMENT OF THE MAINS POWER CABLE

To replace the cable, it is necessary to select the type indicated on the table below and follow the instructions (Fig. 33):

disconnect the appliance from the network  
unscrew the screws located on the rear of the appliance and remove (Fig. 33)

unscrew the screw of the cable clamp  
unscrew the screws in terminal C providing connection and remove the cable

thread the new cable into the cable clamp

Connect the mains cable to the terminal following the diagram:

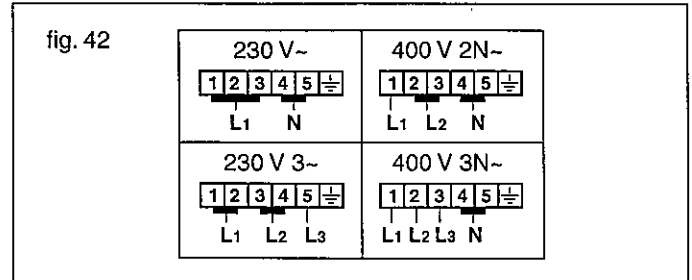

blue cable (neutral) connected to terminal N  
brown live cable connected to terminal L  
yellow/green cable connected to earth terminal (marked "C" in fig. 43).

Tighten the screw of the cable clamp and refit the cooker taking care not to crush the cables.

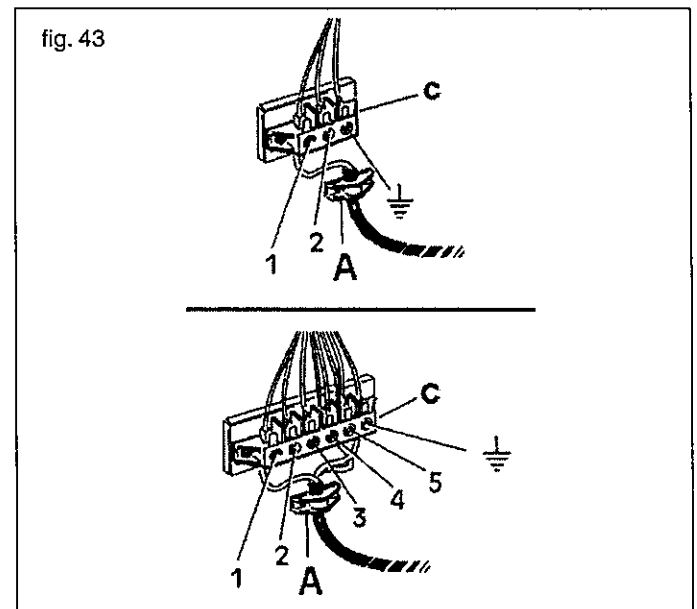

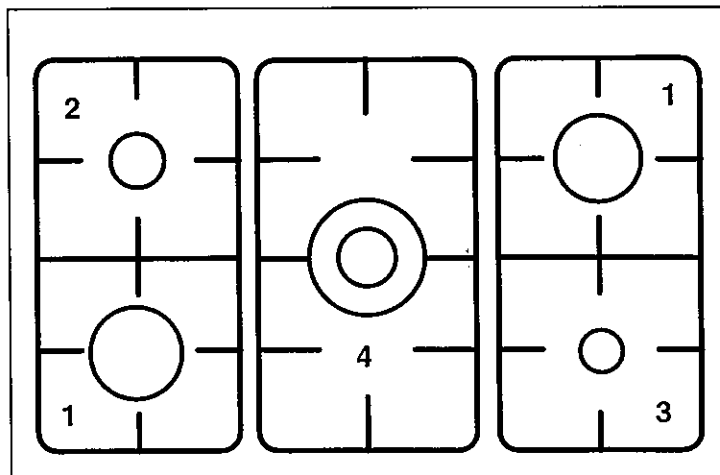

THEMAL CAPACITIES DETERMINED WITH THE HIGH HEATING VALUE OF THE GAS AT 15°C - 1013 mbar

HOB BURNER	Nominal heat input full on W	Nominal heat input reduced W	BUTANE GAS G30 28-30 mbar		PROPANE GAS G31 37 mbar		NATURAL GAS G20 20 mbar	
			injector size Ø 1/100 mm	gr/g	injector size Ø 1/100 mm	gr/g	injector size Ø 1/100 mm	gr/g
Rapid burner R1 L.H.F. or R.H.R.	3000	750	85	218	85	214	115 (Y)	285
Semi-rapid burner B L.H.F. or	1750	460	65	127	65	125	97 (Z)	166
Auxiliary burner A R.H.F.	1000	330	50	73	50	71	72 (X)	95
Central burner BK central of LHF	3300	1350	91	240	91	235	125 (Y)	315

ELECTRIC RIGHT OVEN (STATIC CONVECTION)						
KNOB POSITION	0					Cooker types
ABSORBED POWER W	0	900	600	1500	1500	RIGHT OVEN

ELECTRIC LEFT MULTIFUNCTION OVEN								
KNOB POSITION	1	2	3	4	5	6	7	8
ABSORBED POWER W	2325	2025	57	2257	2057	745	2357	2925

TOTAL ABSORBED ELECTRICAL POWER (Both Ovens: 4.4 Kw)

**GAS HOSE CONNECTION - GUIDANCE NOTE**  
(IF IN DOUBT REFER TO THE CURRENT GAS SAFETY STANDARDS)

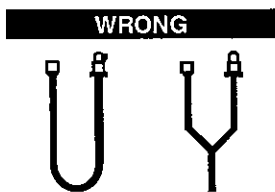

Couplings & hoses should be installed in the same plane as shown on the RIGHT. Do Not Offset Couplings - this causes twisting and undue strain causing premature failure.

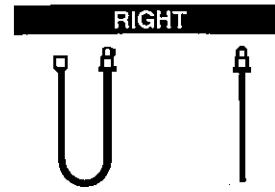

**THE CORRECT WAY TO INSTALL COOKER HOSES FOR VERTICAL TRAVERSE IS TO HAVE A SINGLE, NATURAL LOOP**

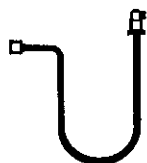

Allowing any sharp bends /as shown on the left) will strain & twist the hose which can cause early failure.



Maintain the minimum or large bending diameter as shown on the right.

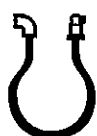

Cooker hoses **Must Not** be fitted horizontally as shown on the left as this will the connections. Where horizontal gas supplies are encountered, the hose must be connected as shown on the right.

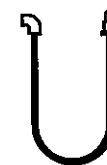

# General Safety Instruction & Troubleshooting

If the appliance is not operating correctly, before calling our Technical Support service, CHECK the following:

## **If the incoming gas flow seems abnormal, ensure that:**

The holes of the burner flame diffusers are not blocked.  
With bottled gas, check that there is still gas in the bottle.  
The pressure regulator is operating.  
The gas tap on the bottle is fully open.

## **SMELL OF GAS IN THE ROOM**

Don't turn electric switches on or off.  
Don't smoke  
Don't use naked flames  
Do turn off the gas at the meter or cylinder  
Do open doors and windows to get rid of the gas  
Call your gas supplier.  
If you are using natural gas in the UK ring British Gas - Trans Co on 0800 111 999  
Ensure that any of the gas taps have not been left open

## **Control knobs or fascia panel too hot**

Is the oven door latching and sealing properly?  
Check that the cooker vents and grills are not blocked.  
When the oven is on DO NOT leave the oven door open for longer periods than necessary. The oven should NOT be used for heating the kitchen, not only does this waste fuel but the control knobs may over heat.

## **Burners will not light**

If only the hotplate burners will not light make sure that the burner parts have been replaced correctly. See instructions on page 24.  
Do the burners spark when you press the knobs? If not is the power on?  
Is the power on? Is the clock illuminated? - If not there may be something wrong with the power supply. Is the cooker supply on at the isolator switch. If the power supply is OK then there is probably something wrong with the ignition system.  
Check that there is not a problem with your gas supply. You can do this by making sure that other gas appliances you may have are working.

## **Power failure**

When power is restored the clock must be reset to the time of day.

## **Food is cooking too slowly, too quickly or burning.**

Cooking time may differ from your previous oven. Check that you are using the recommended temperatures and shelf positions. See page 12. The oven control settings and cooking times are intended to be used only as a guide. Individual tastes may require the temperature to be altered either way, to get the best results you want.

## **Try cooking at a higher shelf position and/or higher temperature.**

Is the oven door latching and sealing properly?

## **The oven is not cooking evenly.**

Check that you are using the recommended temperatures and shelf positions.  
Do not use a tin or tray larger than the baking tray we supplied.  
If you are cooking a large item be prepared to turn it round during cooking.  
If two shelves are used, check that space has been left for the heat to circulate.

## **Conventional Oven**

When the baking tray is put into the oven make sure the tray is pushed to the back of the shelf.  
Check that the door seal is not damaged and that the door catch adjusted so that the door is held firmly against the seal.  
Is the cooker level? A dish of water when placed on the shelf should have the same depth all over. (For example, if it is deeper at the back, then the back of the cooker should be raised up or the front lowered). If the cooker is not level arrange for your supplier to level it for you.  
Do not use the base of the oven for cooking, it is not designed to be used as an extra shelf position.

## **Oven not coming on:**

Is the power on? Is the clock illuminated - if not there may be something wrong with the power supply. Is the cooker supply on at the isolator switch? Check the fuse.  
Is the clock flashing 0.00? If so set to the correct time of day.  
Has the Timer been set to auto by mistake, or after a power cut? If AUTO is showing on the clock press the COOKING DURATION and END TIME buttons to set the oven back to manual.

## **Automatic Cooking**

Timer set correctly but oven knob left OFF by mistake?

## **Automatic Timer faulty**

Is the power on? Is the clock illuminated - if not there may be something wrong with the power supply. Is the cooker supply on at the isolator switch?

## **Smell from the oven**

When you first use your cooker it may give off a slight odour as any protective oils are burnt off but this will stop after a little use.

## **Oven light not coming on**

Is the bulb burned out? Replace with 25 W oven bulb (page 13).

# Additional notes for assembling a safety chain

Please note: the connection hose and the chain are part of the installation not part of the cooker i.e. **THEY ARE NOT SUPPLIED**. They should be provided by your installer and are available at most builders merchants.

The safety chain must be installed in order to:  
Prevent the gas hose from being accidentally damaged when the cooker is moved for cleaning.  
Prevent the cooker from falling over if an excessive weight is placed on the open oven door.

The chain must be anchored to the wall behind the cooker, in a central position with respect to the width of the appliance, in the following manner:

Firmly secure a hook "A" to the wall behind the cooker, on the same level with the fixing points of chain "C".

Fix chain "C" using the screws "B" situated at the back of the cooker (fig. 44).

After having prepared the chain as above, attach in to the hook "A".

#### **WARNING:**

The installer must ensure scrupulous observance of the above points. We declines all responsibility deriving from failure to observe these recommendations.

**FOR GUIDELINES ON THE HOSE CONNECTION REFER TO  
CURRENT GAS SAFETY STANDARDS  
- SEE PAGE 20 ALSO**

fig. 44

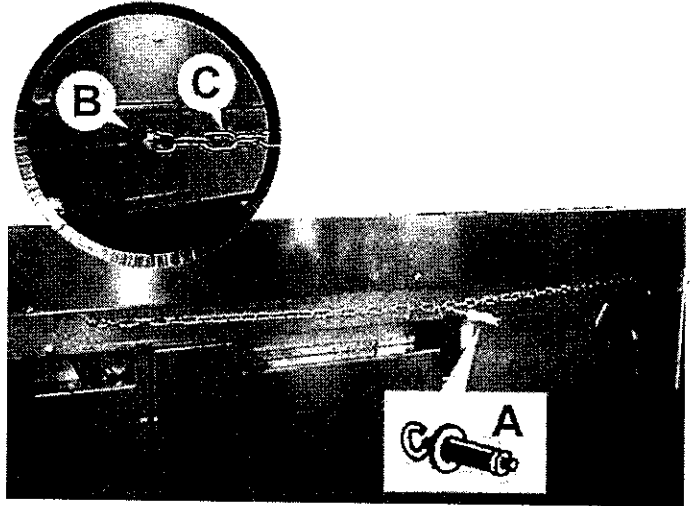

# ***Your guarantee***

## **READ CAREFULLY**

Your new appliance is guaranteed for 12 months against electrical/mechanical breakdown due to faulty manufacture.

This guarantee does not apply to:

- a) Any faults which occur due to accidental damage, installation or misuse of the appliance.
- b) Repair, or interference with, the appliance by any person not authorised by the manufacturer to carry out service.
- c) Any parts which are fitted to the appliance which are not original manufacturer's parts.
- d) Non-domestic use of the machine.
- e) Operation at incorrect voltage.
- f) Consumer advice and consultation purposes.
- g) Cosmetic parts.

The foregoing does not affect your statutory rights.

**Before you call for service:**

**Please read the information given in the user manual.**

**In the event a technician is called out for any of the reasons stated above or for consultation purposes charges will be made to the customer either at the time of visit or at a later time in administration.**

**Heating appliances will rise in temperature within use and retain their heat for a long period after use. Children should be supervised at all times and should not be allowed to touch the surfaces or be in the vicinity of the appliance when in use up until the time the appliance has cooled after use.**



MOD. S100  
COD: 0 42019P XG000  
SERIE N. 0606280017

