



# Red Eléctrica Corporación, S.A. and Subsidiaries

Condensed Consolidated Interim Financial  
Statements

30 June 2020

Consolidated Interim Directors' Report

30 June 2020

(With Limited Review Report thereon)

*(Translation from the original in Spanish. In the event of  
discrepancy, the Spanish-language version prevails.)*



KPMG Auditores, S.L.  
Paseo de la Castellana, 259C  
28046 Madrid

## **Limited Review Report on the Condensed Consolidated Interim Financial Statements**

*(Translation from the original in Spanish. In the event of discrepancy, the Spanish-language version prevails.)*

To the Shareholders of Red Eléctrica Corporación, S.A., commissioned by Company management:

### **REPORT ON THE CONDENSED CONSOLIDATED INTERIM FINANCIAL STATEMENTS**

#### **Introduction**

---

We have carried out a limited review of the accompanying condensed consolidated interim financial statements (the “interim financial statements”) of Red Eléctrica Corporación, S.A. (the “Company”) and subsidiaries (together the “Group”), which comprise the statement of financial position at 30 June 2020, the income statement, statement of comprehensive income, statement of changes in equity, statement of cash flows and the explanatory notes thereto for the six-month period then ended (all condensed and consolidated). The Directors of the Company are responsible for the preparation of these interim financial statements in accordance with International Accounting Standard (IAS) 34 Interim Financial Reporting as adopted by the European Union, for the preparation of condensed interim financial information, pursuant to article 12 of Royal Decree 1362/2007. Our responsibility is to express a conclusion on these interim financial statements based on our limited review.

#### **Scope of Review**

---

We conducted our limited review in accordance with the International Standard on Review Engagements 2410, “Review of Interim Financial Information Performed by the Independent Auditor of the Entity”. A limited review of interim financial statements consists of making inquiries, primarily of persons responsible for financial and accounting matters, and applying analytical and other review procedures. A limited review is substantially less in scope than an audit conducted in accordance with prevailing legislation regulating the audit of accounts in Spain and, consequently, does not enable us to obtain assurance that we would become aware of all significant matters that might be identified in an audit. Accordingly, we do not express an audit opinion on the accompanying interim financial statements.



*(Translation from the original in Spanish. In the event of discrepancy, the Spanish-language version prevails.)*

## **Conclusion**

---

Based on our limited review, which can under no circumstances be considered an audit, nothing has come to our attention that causes us to believe that the accompanying interim financial statements for the six-month period ended 30 June 2020 have not been prepared, in all material respects, in accordance with International Accounting Standard (IAS) 34 "Interim Financial Reporting", as adopted by the European Union, for the preparation of condensed interim financial statements, pursuant to article 12 of Royal Decree 1362/2007.

## **Emphasis of Matter**

---

We draw your attention to the accompanying note 2 a, which states that these interim financial statements do not include all the information that would be required in a complete set of consolidated financial statements prepared in accordance with International Financial Reporting Standards as adopted by the European Union. The accompanying interim financial statements should therefore be read in conjunction with the Group's consolidated annual accounts for the year ended 31 December 2019. This matter does not modify our conclusion.

## **REPORT ON OTHER LEGAL AND REGULATORY REQUIREMENTS**

---

The accompanying consolidated interim directors' report for the six-month period ended 30 June 2020 contains such explanations as the Directors of the Company consider relevant with respect to the significant events that have taken place in this period and their effect on the interim financial statements, as well as the disclosures required by article 15 of Royal Decree 1362/2007. The consolidated interim directors' report is not an integral part of the interim financial statements. We have verified that the accounting information contained therein is consistent with that disclosed in the interim financial statements for the six-month period ended 30 June 2020. Our work is limited to the verification of the consolidated interim directors' report within the scope described in this paragraph and does not include a review of information other than that obtained from the accounting records of Red Eléctrica Corporación, S.A. and subsidiaries.

## **Other Matter**

---

This report has been prepared at the request of Company management in relation to the publication of the six-monthly financial report required by article 119 of Royal Legislative Decree 4/2015 of 23 October 2015, which approved the Revised Securities Market Law enacted by Royal Decree 1362/2007 of 19 October 2007.

KPMG Auditores, S.L.

*(Signed on original in Spanish)*

Eduardo González Fernández  
28 July 2020



**Condensed Consolidated Interim  
Financial Statements and  
Consolidated Interim Directors'  
Report for the six-month period  
ended 30 June 2020**

(Free translation from the original in Spanish. In the event of discrepancy, the Spanish-language version prevails.)



## Red Eléctrica Group

### Consolidated Statement of Financial Position at 30 June 2020 and 31 December 2019

Thousands of Euros			
Assets	Note	30.06.2020	31.12.2019 (*)
<b>Intangible assets</b>	7	745,028	737,142
<b>Property, plant and equipment</b>	7	9,583,462	9,673,135
<b>Investment property</b>	7	1,335	1,345
<b>Equity-accounted investees</b>	8	536,642	259,594
<b>Non-current financial assets</b>	13	121,998	112,571
<b>Non-current derivatives</b>	13	22,417	14,732
<b>Deferred tax assets</b>	15	67,206	66,009
<b>Other non-current assets</b>	13	3,057	3,869
<b>Total non-current assets</b>		11,081,145	10,868,397
<b>Inventories</b>	9	43,983	42,720
<b>Trade and other receivables</b>	10	1,304,112	1,346,007
<b>Other current financial assets</b>	13	28,288	58,200
<b>Current derivatives</b>	13	18,012	11,311
<b>Cash and cash equivalents</b>		568,116	328,570
<b>Total current assets</b>		1,962,511	1,786,808
<b>Total assets</b>		13,043,656	12,655,205
<b>Equity and Liabilities</b>			
<b>Capital and reserves</b>		3,471,370	3,564,982
Capital		270,540	270,540
Reserves		2,910,478	2,763,196
Own shares (-)		-41,355	-36,504
Profit attributable to the Parent		331,707	714,752
Interim dividend (-)		0	-147,002
<b>Valuation adjustments</b>		-141,135	-52,466
Financial assets at fair value through other comprehensive income		15,597	24,604
Hedging transactions		-80,309	-82,699
Translation differences		-76,423	5,629
<b>Equity attributable to the Parent</b>		3,330,235	3,512,516
<b>Non-controlling interests</b>		68,940	72,640
<b>Total equity</b>	11	3,399,175	3,585,156
<b>Grants and other</b>		716,212	705,762
<b>Non-current provisions</b>		161,634	151,406
<b>Non-current financial liabilities</b>	13	6,578,219	5,327,609
Loans and borrowings, bonds and other marketable securities		6,519,282	5,267,323
Other non-current financial liabilities		58,937	60,286
<b>Deferred tax liabilities</b>	15	436,316	466,283
<b>Non-current derivatives</b>	13	39,658	48,266
<b>Other non-current liabilities</b>	13	98,471	94,902
<b>Total non-current liabilities</b>		8,030,510	6,794,228
<b>Current provisions</b>		21,838	27,345
<b>Current financial liabilities</b>	13	1,187,628	1,846,537
Loans and borrowings, bonds and other marketable securities		380,704	1,197,981
Other current financial liabilities		806,924	648,556
<b>Trade and other payables</b>	14	402,447	396,943
Suppliers		283,181	311,879
Other payables		51,945	61,490
Current tax liabilities		67,321	23,574
<b>Current derivatives</b>	13	2,058	4,996
<b>Total current liabilities</b>		1,613,971	2,275,821
<b>Total equity and liabilities</b>		13,043,656	12,655,205

(\*) Figures restated as a result of the recognition of the Hispasat business combination, effective 3 October 2019 (see notes 2.f and 6) Notes 1 to 22 and Appendix I form an integral part of these condensed consolidated interim financial statements.



## Red Eléctrica Group

### Consolidated Income Statement for the Periods Ended 30 June 2020 and 2019

Thousands of Euros	Note	30.06.2020	30.06.2019
Revenue	16.a	977,892	993,074
Self-constructed assets	7	26,713	25,663
Share of profit of equity-accounted investees (with a similar activity to that of the Group)	8	8,007	3,639
Supplies	16.c	(13,436)	(13,923)
Other operating income	16.b	10,961	7,779
Personnel expenses	16.d	(87,483)	(77,023)
Other operating expenses	16.c	(156,405)	(159,848)
Depreciation and amortisation	7	(271,679)	(246,757)
Non-financial and other capital grants		15,354	12,104
Impairment and losses on disposal of fixed assets		(660)	(1)
<b>Results from operating activities</b>		<b>509,264</b>	<b>544,707</b>
Finance income		8,697	6,667
Finance costs		(75,358)	(71,004)
Exchange (gains)/losses		(2,885)	511
<b>Net finance cost</b>		<b>(69,546)</b>	<b>(63,826)</b>
<b>Profit before tax</b>		<b>439,718</b>	<b>480,881</b>
Income tax		(108,050)	(118,685)
<b>Consolidated profit for the period</b>		<b>331,668</b>	<b>362,196</b>
<b>A) Consolidated profit for the period attributable to the Parent</b>		<b>331,707</b>	<b>362,199</b>
<b>B) Consolidated loss for the period attributable to non-controlling interests</b>	2.e	<b>(39)</b>	<b>(3)</b>
<b>Earnings per share in Euros</b>			
Basic earnings per share in Euros	21	0.62	0.67
Diluted earnings per share in Euros	21	0.62	0.67

Notes 1 to 22 and Appendix I form an integral part of these condensed consolidated interim financial statements.



## Red Eléctrica Group

## Consolidated Statement of Comprehensive Income for the Periods Ended 30 June 2020 and 2019

Thousands of Euros	30.06.2020	30.06.2019
<b>A) Consolidated profit for the period (income statement)</b>	<b>331,668</b>	<b>362,196</b>
<b>B) Other comprehensive income - Items that will not be reclassified to profit or loss:</b>	<b>(7,824)</b>	<b>(2,985)</b>
1. Revaluation/(reversal) of PPE and intangible assets	-	-
2. Actuarial gains and losses	1,577	(3,135)
3. Share of other comprehensive income from investments in joint ventures and associates	-	-
4. Equity instruments through other comprehensive income	(9,007)	(634)
5. Other income and expense that will not be reclassified to profit or loss	-	-
6. Tax effect	(394)	784
<b>C) Other comprehensive income - Items that could be reclassified to profit or loss:</b>	<b>(83,323)</b>	<b>(29,924)</b>
<b>1. Cash flow hedges:</b>	<b>13,436</b>	<b>(25,759)</b>
a) Revaluation gains/(losses)	9,731	(28,113)
b) Amounts transferred to the income statement	3,705	2,354
c) Amounts transferred to initial value of hedged items	-	-
d) Other reclassifications	-	-
<b>2. Translation differences:</b>	<b>(114,285)</b>	<b>1,073</b>
a) Revaluation gains/(losses)	(114,285)	1,073
b) Amounts transferred to the income statement	-	-
c) Other reclassifications	-	-
<b>3. Share of other comprehensive income from investments in joint ventures and associates:</b>	<b>(7,686)</b>	<b>(11,410)</b>
a) Revaluation gains/(losses)	(7,686)	(11,410)
b) Amounts transferred to the income statement	-	-
c) Other reclassifications	-	-
<b>4. Debt instruments at fair value through other comprehensive income:</b>	<b>-</b>	<b>-</b>
a) Revaluation gains/(losses)	-	-
b) Amounts transferred to the income statement	-	-
c) Other reclassifications	-	-
<b>5. Other income and expense that could subsequently be reclassified to profit or loss:</b>	<b>-</b>	<b>-</b>
a) Revaluation gains/(losses)	-	-
b) Amounts transferred to the income statement	-	-
c) Other reclassifications	-	-
<b>6. Tax effect</b>	<b>25,212</b>	<b>6,172</b>
<b>Total comprehensive income for the period (A + B + C)</b>	<b>240,521</b>	<b>329,287</b>
a) Attributable to the Parent	244,221	329,281
b) Attributable to non-controlling interests	(3,700)	6

Notes 1 to 22 and Appendix I form an integral part of these condensed consolidated interim financial statements.



**Red Eléctrica Group**  
**Consolidated Statement of Changes in Equity for the Periods Ended 30 June 2020 and 2019**

Equity / Thousands of Euros	Note	Subscribed capital	Reserves	Own shares	Profit attributable to the Parent	Valuation adjustments	Non-controlling interests	Total equity
<b>Balances at 1 January 2019</b>		<b>270,540</b>	<b>2,450,810</b>	<b>(21,303)</b>	<b>704,558</b>	<b>(44,071)</b>	<b>832</b>	<b>3,361,366</b>
<b>I. Comprehensive income for the period</b>		-	<b>(2,350)</b>	-	<b>362,199</b>	<b>(30,568)</b>	<b>6</b>	<b>329,287</b>
<b>II. Transactions with shareholders or owners</b>		-	<b>(235,219)</b>	<b>(2,718)</b>	<b>(147,250)</b>	-	-	<b>(385,187)</b>
- Distribution of dividends		-	(237,133)	-	(147,250)	-	-	(384,383)
- Transactions with own shares		-	1,914	(2,718)	-	-	-	(804)
<b>III. Other changes in equity</b>		-	<b>557,308</b>	-	<b>(557,308)</b>	-	-	-
- Transfers between equity line items		-	557,308	-	(557,308)	-	-	-
- Other changes		-	-	-	-	-	-	-
<b>Balances at 30 June 2019</b>		<b>270,540</b>	<b>2,770,549</b>	<b>(24,021)</b>	<b>362,199</b>	<b>(74,639)</b>	<b>838</b>	<b>3,305,466</b>
<b>Balances at 31 December 2019</b>		<b>270,540</b>	<b>2,616,194</b>	<b>(36,504)</b>	<b>718,040</b>	<b>(52,466)</b>	<b>98,630</b>	<b>3,614,434</b>
Restated due to Hispasat business combination (*)		-	-	-	(3,288)	-	(25,990)	(29,277)
<b>Balances at 1 January 2020 (*)</b>		<b>270,540</b>	<b>2,616,194</b>	<b>(36,504)</b>	<b>714,752</b>	<b>(52,466)</b>	<b>72,640</b>	<b>3,585,156</b>
<b>I. Comprehensive income for the period</b>		-	<b>1,183</b>	-	<b>331,707</b>	<b>(88,669)</b>	<b>(3,700)</b>	<b>240,521</b>
<b>II. Transactions with shareholders or owners</b>		-	<b>146,960</b>	<b>(4,851)</b>	<b>(568,611)</b>	-	-	<b>(426,502)</b>
- Distribution of dividends		-	147,002	-	(568,611)	-	-	(421,609)
- Transactions with own shares		-	(42)	(4,851)	-	-	-	(4,893)
<b>III. Other changes in equity</b>		-	<b>146,141</b>	-	<b>(146,141)</b>	-	-	-
- Transfers between equity line items		-	146,141	-	(146,141)	-	-	-
- Other changes		-	-	-	-	-	-	-
<b>Balances at 30 June 2020</b>		<b>270,540</b>	<b>2,910,478</b>	<b>(41,355)</b>	<b>331,707</b>	<b>(141,135)</b>	<b>68,940</b>	<b>3,399,175</b>

(\*) Figures restated as a result of the recognition of the Hispasat business combination, effective 3 October 2019 (see notes 2.f and 6)

Notes 1 to 22 and Appendix I form an integral part of these condensed consolidated interim financial statements.





## Red Eléctrica Group Consolidated Statement of Cash Flows for the Periods Ended 30 June 2020 and 2019

Thousands of Euros	Note	30.06.2020	30.06.2019
<b>Cash flows from operating activities</b>		<b>580,463</b>	<b>539,918</b>
<b>Profit before tax</b>		<b>439,718</b>	<b>480,881</b>
<b>Adjustments for:</b>		<b>330,184</b>	<b>301,962</b>
Depreciation and amortisation	7	271,679	246,757
Other adjustments		58,505	55,205
Equity-accounted investees		(8,007)	(3,639)
Losses on disposal/impairment of non-current assets and financial instruments		660	1
Accrued finance income		(8,697)	(6,667)
Accrued finance costs		75,358	71,005
Charge to/surplus provisions for liabilities and charges		14,545	6,609
Capital and other grants taken to income		(15,354)	(12,104)
<b>Changes in operating assets and liabilities</b>		<b>(36,615)</b>	<b>(73,932)</b>
Changes in inventories, receivables, current prepayments and other current assets		40,375	(116,600)
Changes in trade payables, current contract liabilities and other current liabilities		(76,990)	42,668
<b>Other cash flows used in operating activities:</b>		<b>(152,824)</b>	<b>(168,993)</b>
Interest paid		(104,739)	(105,021)
Dividends received		4,848	4,848
Interest received		2,992	898
Income tax received/(paid)		(55,895)	(68,112)
Other proceeds from and payments for operating activities		(30)	(1,606)
<b>Cash flows used in investing activities</b>		<b>(638,796)</b>	<b>(183,211)</b>
<b>Payments for investments</b>		<b>(652,780)</b>	<b>(226,737)</b>
Property, plant and equipment, intangible assets and investment property		(278,518)	(226,737)
Group companies, associates and business units		(374,262)	-
Other financial assets		-	-
<b>Proceeds from sale of investments</b>		<b>3,463</b>	<b>24,549</b>
Property, plant and equipment, intangible assets and investment property		144	-
Other financial assets		3,319	24,549
<b>Other cash flows from investing activities</b>		<b>10,521</b>	<b>18,977</b>
Other proceeds from investing activities		10,521	18,977
<b>Cash flows from (used in) financing activities</b>		<b>300,773</b>	<b>(270,446)</b>
<b>Proceeds from and payments for equity instruments</b>		<b>(4,892)</b>	<b>(804)</b>
Acquisition		(22,852)	(38,665)
Disposal		17,960	37,861
<b>Proceeds from and payments for financial liability instruments</b>	13	<b>472,781</b>	<b>(119,069)</b>
Issue and drawdowns		1,572,765	568,471
Redemption and repayment		(1,099,984)	(687,540)
<b>Dividends and interest on other equity instruments paid</b>	11	<b>(147,002)</b>	<b>(147,250)</b>
<b>Other cash flows used in financing activities</b>		<b>(20,114)</b>	<b>(3,323)</b>
Interest paid		(90)	(55)
Other proceeds from and payments for financing activities		(20,024)	(3,268)
<b>Effect of exchange rate fluctuations on cash and cash equivalents</b>		<b>(2,894)</b>	<b>207</b>
<b>Net increase in cash and cash equivalents</b>		<b>239,546</b>	<b>86,468</b>
Cash and cash equivalents at beginning of period		328,570	767,152
Cash and cash equivalents at end of period		568,116	853,620

Notes 1 to 22 and Appendix I form an integral part of these condensed consolidated interim financial statements.



## Contents

1. Activities of the Group Companies.....	7
2. Basis of Presentation of the Consolidated Interim Financial Statements .....	7
3. Sector Regulation .....	9
4. Significant Accounting Policies .....	11
5. Considerations regarding COVID-19 with respect to the Consolidated Interim Financial Statements .....	11
6. Business Combinations.....	14
7. Intangible Assets, Property, Plant and Equipment and Investment Property .....	17
8. Equity-accounted Investees .....	18
9. Inventories .....	19
10. Trade and Other Receivables .....	19
11. Equity.....	20
12. Financial Risk Management Policy .....	22
13. Financial Assets, Financial Liabilities and Derivatives.....	25
14. Trade and Other Payables .....	29
15. Taxation .....	30
16. Income and Expenses .....	30
17. Transactions with Equity-accounted Investees and Related Parties .....	32
18. Remuneration of the Board of Directors.....	33
19. Remuneration of Senior Management .....	35
20. Segment Reporting .....	36
21. Earnings per Share.....	39
22. Events after 30 June 2020.....	39
<b>Appendix I: Details of equity investments at 30 June 2020.....</b>	<b>40</b>

In order to facilitate comprehension of the information provided in this document, certain alternative performance measures have been included. The definition of these measures can be found at [www.ree.es](http://www.ree.es).



## 1. Activities of the Group Companies

---

Red Eléctrica Corporación, S.A. (hereinafter the Parent or the Company) is the Parent of a Group formed by subsidiaries. The Group is also involved in joint operations along with other operators. The Parent and its subsidiaries form the Red Eléctrica Group (hereinafter the Group or Red Eléctrica Group). The Company's registered office is located in Alcobendas (Madrid) and its shares are traded on the Spanish automated quotation system as part of the selective IBEX-35 index.

The Group's principal activity is electricity transmission, system operation and management of the transmission network for the Spanish electricity system. These regulated activities are carried out through Red Eléctrica de España, S.A.U. (hereinafter REE).

The Group also conducts electricity transmission activities outside Spain through Red Eléctrica Internacional, S.A.U. (hereinafter REI) and its investees. Furthermore, the Group provides telecommunications services to third parties through Red Eléctrica Infraestructuras de Telecomunicación, S.A.U. (hereinafter REINTEL), essentially via dark fibre backbone network rental, and through the HISPASAT Group, by means of satellite infrastructure operation.

In addition the Group carries out activities through its subsidiaries aimed at financing its operations and covering risks by reinsuring its assets and activities. It also develops and builds electricity infrastructure and facilities through its subsidiaries and/or investees, Red Eléctrica Infraestructuras en Canarias, S.A.U. (REINCAN) and Interconexión Eléctrica Francia-España, S.A.S. (INELFE). Moreover, the Group carries out activities aimed at driving and fostering technological innovation through its subsidiary Red Eléctrica y de Telecomunicaciones, Innovación y Tecnología, S.A.U. (RETIT).

Appendix I provides details of the activities and registered offices of the Parent and its subsidiaries, as well as the direct and indirect investments held by the Parent in the subsidiaries.

## 2. Basis of Presentation of the Consolidated Interim Financial Statements

---

### a) General information

The accompanying consolidated interim financial statements have been prepared by the directors of the Parent to give a true and fair view of the consolidated equity and consolidated financial position of the Company and its subsidiaries at 30 June 2020, as well as the consolidated results of operations and consolidated cash flows and changes in consolidated equity for the six-month period then ended.

The accompanying consolidated interim financial statements, authorised for issue by the Company's directors at their board meeting held on 28 July 2020, have been prepared on the basis of the individual accounting records of the Company and the other Group companies, which together form the Red Eléctrica Group (see Appendix I). Each company prepares its financial statements applying the accounting principles and criteria in force in its country of operations. Accordingly, the adjustments and reclassifications necessary to harmonise these principles and criteria with International Financial Reporting Standards as adopted by the European Union (IFRS-EU) have been made on consolidation. The accounting policies of the consolidated companies are changed when necessary to ensure their consistency with the principles adopted by the Company.

The consolidated interim financial statements of the Red Eléctrica Group for the six-month period ended 30 June 2020 have been prepared in accordance with IAS 34 Interim Financial Reporting and are presented in thousands of Euros (except where otherwise indicated).

Pursuant to IAS 34, interim financial reporting is only intended to provide an update on the content of the latest consolidated annual accounts drawn up by the Group, focusing on new activities, events and circumstances occurring during the six-month period, without repeating the information previously published in the consolidated annual accounts for 2019. Therefore, to enable an adequate understanding of the information disclosed in these consolidated interim financial statements, they should be read in conjunction with the consolidated annual accounts of the Group for the year ended 31



December 2019, which were prepared in accordance with the International Financial Reporting Standards as adopted by the European Union (IFRS-EU) in force.

The Group has not omitted any mandatory accounting principle with a material effect on the consolidated interim financial statements.

The consolidated annual accounts for 2019 were approved by the shareholders at their general meeting held on 14 May 2020.

#### b) New IFRS-EU and IFRIC interpretations

These consolidated interim financial statements take into account the new standards and improvements to International Financial Reporting Standards published and effective as of 1 January 2020. These standards and improvements have not had a significant impact on the Group's consolidated interim financial statements. Details are as follows

Effective from:	New requirements or amendments
1 January 2020	<ul style="list-style-type: none"> <li>Amendments to IFRS 3 - Definition of a Business</li> </ul>
	<ul style="list-style-type: none"> <li>Amendments to IAS 1 and IAS 8 - Definition of Material</li> </ul>
	<ul style="list-style-type: none"> <li>Amendments to IFRS 9, IAS 39 and IFRS 7 - Interest Rate Benchmark Reform (IBOR)</li> </ul>
Pending adoption by the EU	<ul style="list-style-type: none"> <li>Amendments to IFRS 16 Leases - Improvements relating to lease income</li> </ul>

With regard to the IBOR reform, the Group has various hedging relationships to hedge interest rate risk, using derivatives and underlyings whose benchmark rate is generally the EURIBOR. No hedging relationships have been affected thus far, and moreover, the Group is only minimally exposed to intraday benchmark interest rates (EONIA). With respect to the EURIBOR, in 2019 a new hybrid calculation methodology was developed based on actual market transactions, which distinguishes between three levels of estimates, depending on the extent to which such transactions are observable. This new methodology was approved by the authorities, and therefore no amendments to existing or future contracts are expected to be required, on considering that these financial instruments are not exposed to a high level of uncertainty at 30 June 2020.

The remaining benchmark interest rates are undergoing a reform on a global scale, although this is not expected to affect the long-term hedging relationships currently in place. The Group has adopted a proactive stance with respect to this process, carrying out its monitoring and analysis sufficiently in advance to prevent any negative impacts that may arise. On this basis, the benchmark interest rate reform is not expected to have a significant impact on the Group's financial statements.

#### c) Estimates and assumptions

The preparation of the consolidated interim financial statements in accordance with IFRS-EU requires Group management to make judgements, estimates and assumptions that affect the application of accounting standards and the amounts of assets, liabilities, income and expenses. Estimates and assumptions are based on past experience and other factors that are considered reasonable under the circumstances. Actual results may differ from these estimates. These financial statements have been prepared on a going concern basis.

These estimates are based on the best information available as described in note 2c) to the consolidated annual accounts for 2019, Estimates and assumptions. In 2020 the Group has re-estimated the useful life of certain national transmission assets, as detailed in note 7.

#### d) Consolidation principles

The same consolidation principles have been used in these consolidated interim financial statements as in the consolidated annual accounts for 2019.



### e) Changes in the consolidated Group

On 31 January 2020 the Brazilian company “Red Eléctrica Brasil Holding LTDA” (hereinafter REB) was incorporated. This company’s statutory activity mainly consists of the acquisition, holding, management and administration of securities. This company is wholly owned by Red Eléctrica Internacional, S.A.U.

On 25 March 2020, once the conditions precedent laid down in the purchase agreement had been met, a 50% interest was acquired in the Brazilian company “Energia Empreendimentos e Participações S.A.” and subsidiaries (hereinafter ARG0 Energia). This company’s statutory activity mainly consists of the acquisition, holding, management and administration of securities. This company is the parent of a group of electricity transmission concession operator companies in Brazil. Red Eléctrica Brasil (REB) holds a 50% interest in this company. It is accounted for using the equity method.

### f) Comparative information

Having completed the purchase price allocation in 2020 for the acquisition of the Hispasat Group on 3 October 2019, the Company has restated the comparative information presented in the consolidated annual accounts for the year ended 31 December 2019 (see note 6). In addition, it has recognised goodwill in the percentage of the net assets acquired, and the non-controlling interest in the amount of the proportionate share of the net assets. At 31 December, upon the provisional recognition of the business combination, goodwill had been recognised for all of the net assets acquired. Due to the acquisition of the Hispasat group on 3 October 2019, the consolidated interim financial statements at 30 June 2020 are not directly comparable with the prior period.

## 3. Sector Regulation

---

### a) Electricity sector in Spain

As reflected in the consolidated annual accounts presented at 31 December 2019, the regulatory framework for the electricity sector currently in force is based on Electricity Industry Law 24/2013 of 26 December 2013.

The consolidated annual accounts for 2019 also reflect the new remuneration framework for the electricity transmission and system operation activities, applicable from 1 January 2020 onwards, which is set forth in the Spanish National Markets and Competition Commission (CNMC) Circulars published in November and December 2019.

Among the main legislative developments published for the electricity sector during the first half of 2020, it is important to highlight all the emergency legislation that was published following the royal decree-law declaration of a state of emergency to address the health and economic crisis resulting from COVID-19.

Especially worthy of mention for the electricity sector are Royal Decree-Law 11/2020 of 31 March 2020, introducing supplementary urgent economic and social measures to address the impact of COVID-19, and Royal Decree-Law 23/2020 of 23 June 2020, approving measures for economic recovery in the field of energy and other areas.

The provisions of the first of these two pieces of legislation include a number of measures to protect electricity consumers with respect to the crisis. Meanwhile, the second of the royal decree-laws mentioned in the previous paragraph contains a number of provisions to encourage a green exit from the crisis by speeding up the energy transition, in line with the EU’s European Green Deal.

The updated draft integrated National Energy and Climate Plan (NECP) for 2021-2030 being submitted to the European Commission, following its approval by the Council of Ministers, marks another major milestone for 2020 to date. The NECP is the strategic planning tool that sets out the Spanish government’s energy and climate policy for the coming decade. It forms part of the Strategic Energy and Climate Framework, alongside the draft bill on Climate Change and Energy Transition and the Fair Transition Strategy.



The draft bill on Climate Change and Energy Transition was likewise approved by the Council of Ministers, on 19 May 2020, before being submitted to the Spanish parliament for processing. The target laid down in the proposed legislation is for renewable energies to make up at least 35% of final energy consumption. The target for the electricity system in particular is for renewables to represent at least 70% by 2030, aiming to be climate-neutral by 2050.

Meanwhile, on 24 January 2020 the CNMC published Circular 3/2020 of 15 January 2020, establishing the methodology for calculating electricity transmission and distribution tolls. The purpose of the Tolls Circular is to determine how the annual cost of the remuneration for electricity transmission and distribution networks should be allocated among the different categories of agents connected to those networks.

Lastly, while not of a legislative nature, the report published by the CNMC on the initial proposal of the System Operator and Transmission Network Manager for development of the electricity transmission network for the 2021-2026 period is also worth highlighting.

As regards the remuneration for the transmission activity, and more specifically for the assets that came into service before 1 January 1998, Red Eléctrica sought an extension to the useful life of these facilities, although its request was dismissed in a Decision of the Directorate-General for Energy Policy and Mines (DGPEM). An appeal for judicial review was therefore lodged with the High Court of Justice of Madrid, which was likewise dismissed. An ancillary suit for nullity of proceedings was subsequently filed with the High Court. This ancillary suit for nullity of proceedings was dismissed by the High Court on 5 June. However, the dismissal has no impact on the Group's financial statements.

Moreover, in relation to the appeal for judicial review filed with the High Court by the administrative authorities in April 2018 against Ministry of Industry, Energy and Tourism Order IET/981/2016 setting the remuneration for the transmission activity for 2016, whereby a review of certain remuneration parameters was broached, on 29 June this year notice was received of the High Court judgment. The judgment partially upholds the declaration that Order IET 981/2016 is detrimental to the public interest and accepts certain arguments brought forward by the Company, prompting the regulator to revise the calculation methodology for certain parameters subject to review. While awaiting the final decision on this review, the Company considers that, on the basis of the information available to date, this risk is reasonably covered. This assessment will be updated as and when more insight is gained into how the regulator will set the aforementioned methodology.

## **b) International electricity sector**

There have been no significant legislative developments for the sector since the publication of the consolidated annual accounts at 31 December 2019.

Since 25 March, the Group has also been operating in the electricity sector in Brazil through ARGO Energía, in which REB holds a 50% interest. The main regulatory features of this sector are as follows:

### **Electricity sector in Brazil**

The electricity transmission model in force in Brazil is based on public concessions, which are put out to tender. The Brazilian Electricity Regulatory Agency (ANEEL) promotes the auctions for contracting energy and transmission, while the power to grant the concessions falls to the Brazilian Ministry of Mines and Energy (MME).

Federal Laws No. 8,987/1995 and No. 9,074/1995 stipulate which backbone network facilities will be subject to auction (*leilão*) and operated pursuant to the indications of ANEEL, which regulates and inspects the generation, transmission, distribution and supply of electricity in Brazil. ANEEL Resolution No. 64 of June 2004 specifies the composition of the backbone network of the National Interconnected System (SIN) and Other Transmission Facilities (DIT).

Law No. 12,782/2013 sets a concession term of 30 years as of the execution date of the concession agreement. This term may be extended at the regulator's discretion, and the deadline for facilities to start operating ranges between 18 and 60 months (included in the 30-year period).





At the auction, the transmission agents bid for the annual revenue receivable for each batch over the term of the agreement (RAP – *Receita Anual Permitida*) from the date the asset comes into service up to the expiry date of the agreement.

The technical and commercial terms and conditions for the provision of the transmission service are laid down in the transmission service agreement (*Contrato de Prestação de Serviços de Transmissão – CPST*) in place between the Brazilian National Electricity System Operator (*Operador Nacional do Sistema Elétrico – ONS*), which operates, oversees and controls electricity generation within the SIN and also manages the electricity transmission system (backbone network), and the public service transmission concession operators.

#### c) Regulation of the telecommunications sector

There have been no significant legislative developments for the sector since the publication of the consolidated annual accounts at 31 December 2019.

## 4. Significant Accounting Policies

---

The same accounting principles have been used in these consolidated interim financial statements as in the consolidated annual accounts for 2019, with the exception of those arising from the new IFRS-EU (see note 2 b), which have not had a significant impact on the consolidated interim financial statements.

## 5. Considerations regarding COVID-19 with respect to the Consolidated Interim Financial Statements

---

The emergence of Coronavirus disease 2019 (COVID-19) in China early in the year and its rapid spread to a number of countries across the globe led the World Health Organization (WHO) to declare the viral outbreak a pandemic by mid-March.

In Spain, the healthcare situation stemming from the COVID-19 pandemic called for the government to take exceptional measures. It did so by publishing Royal Decree 463/2020 declaring a nationwide state of emergency, which was subsequently extended on more than one occasion and was lifted on 21 June. As was apparent in the Royal Decree and the accompanying regulations issued during the more than three months that the state of emergency remained in force, the need to guarantee the supply of energy in general, and electricity in particular, was a priority.

Considering the complexity of the health crisis, the substantially global nature of the markets in this day and age, and the fact that there is as yet no effective medical treatment for the virus, it is not possible at present to determine with any precision all of the consequences that this crisis, and the ensuing recovery period, will have on the Group's activities. The consequences will largely depend on the amount of time needed to completely eradicate the pandemic, as well as the capacity to recover and resume global economic activity at pre-crisis levels.

The Red Eléctrica Group and more specifically Red Eléctrica de España, as the electricity transmission infrastructure owner and system manager, has remained fully committed to achieving the targets defined by the Spanish authorities, having implemented a number of extraordinary measures in order to meet its obligations as laid down in Law 24/2013, aimed at ensuring continuity and security of supply. These measures have been executed in parallel with the priority of guaranteeing the health of the Company's employees and observing the health authorities' policy to slow the spread.

Within this context, Red Eléctrica has followed the guidelines adapted to the recommendations issued by the different pertinent authorities in Spain as well as in each market of operations, with the priority of preserving the health and safety of all of its employees, customers and suppliers.



With this in mind, measures were implemented to allow for flexibility and to enable all staff whose physical presence in the workplace was not strictly necessary to work from home, so as to guarantee security of supply for electricity and telecommunications. Implementation of this measure was only possible thanks to the Company's considerable efforts in recent years in terms of employee training and to equip all staff with the IT and communications resources needed to address a situation such as the present one.

Red Eléctrica de España has spared no efforts or resources when it comes to rolling out whatever measures have become necessary to ensure that the electricity system remains up and running in these critical times. By way of example, the Company set up a third electricity control centre in record time.

At 30 June all facilities operation and maintenance activities in Spain have fully resumed and the construction of new infrastructure is now underway again, while all measures temporarily put in place to ensure network availability and to resolve incidents and faults have been lifted.

In Latin America, the pandemic has still not come under control at 30 June in the countries where the Group is mainly present (Chile, Peru and Brazil), and lockdown measures remain in force in some of these countries. Nonetheless, facilities operation and maintenance activities are ongoing with no issues.

Home-working has been implemented on a large scale, IT and telecommunications systems are responding correctly, and the ordinary operations of the different Group companies have not been particularly affected.

No incidents occurred during the state of emergency in Spain that posed a risk as regards meeting electricity demand and keeping the system up and running correctly; neither were any transmission network incidents recorded that in any way compromised the operation of the Spanish electricity system.

However, the decline in demand for electricity in Spain over this half-year has entailed a significant challenge as regards system operation, and adequate voltage controls have had to be implemented in the Spanish electricity system. Additional energy scheduling in view of technical restrictions due to voltage controls and more intensive use of available resources in the transmission network has enabled the exceptional situation stemming from COVID-19 to be managed with no incidents.

Moreover, both the international electricity infrastructure business and the telecommunications business have been providing essential services with no incidents arising.

From a financial and economic perspective, throughout this period the Group's financial position has been robust, enabling it to confront these difficult times through measures aimed at bolstering its liquidity. In the first half of 2020 the Group made two bond issues for a total amount of Euros 1,100 million, by way of Euros 700 million in January and Euros 400 million in April, and also entered into loan and credit facility agreements amounting to Euros 475 million (see note 12). Following these transactions, and having already settled the debts that matured during this first half of the year and the payments arising from the acquisition of Argo Energía in Brazil, the Group's liquidity position at the end of June stands at Euros 2,523 million, specifically Euros 568 million in available cash and Euros 1,955 million in available credit facilities. This position ensures the Group's ability to meet its operating cash flow requirements, to honour debt maturities for the remainder of this year and for the coming years, and to address any adverse situations that could emerge in the financial markets over the coming months as a result of developments in the current crisis (see note 12). Between now and 2022 the Group will need to repay debt amounting to Euros 1,479 million – Euros 265 million by the end of 2020, Euros 166 million in 2021 and Euros 1,048 million in 2022 (see note 12).

Since the onset of the crisis, the Group has been continuously monitoring the estimates of the quantitative impact that the situation arising from management of the COVID-19 effect could have on its profits and its investments in projects underway. Moreover, as already mentioned, at the date of authorising these financial statements for issue it is not possible to determine accurately the consequences of this situation, or when and to what extent recovery will be achieved. However, the following conclusions can be drawn from the scenarios analysed:





- Although in certain weeks during the state of emergency the demand for electricity in Spain fell by almost 20% compared to equivalent periods in 2019, the state of emergency having recently drawn to a close, economic activity has now resumed and electricity consumption has thus also risen; as such, in the last week of this first half of the year the drop vis-à-vis the same period of 2019 was approximately 10%.

In Latin America – specifically Chile, Peru and Brazil – the fall in electricity demand was 30% in Peru and more than 10% in Brazil, while in Chile the decline in demand was not significant, inasmuch as mining activity was not halted due to the pandemic.

In addition, revenue from telecommunications activities in this first half of the year, particularly that generated by services associated with fibre optic networks, have not been significantly impacted by COVID-19. There has, however, been a negative deviation in forecast sales of satellite services, given that these services are provided in both Europe and Latin America (see note 16).

Most of the sectors in which the greatest volume of the Group's operations in Spain and Latin America is concentrated are regulated sectors, with limited exposure to demand risk; the impact on overall revenue for 2020 is therefore not expected to be significant, despite uncertainties that have not yet dissipated.

- Construction of new infrastructure in both Spain and Latin America has been somewhat delayed due to economic activity being completely or partially brought to a standstill at the behest of the different authorities.

Activity has now resumed in Spain and the pace is expected to pick up over the coming months, enabling part of the deviation accumulated at 30 June to be offset in the second half of the year. Nonetheless, at the end of this year investments could fall short of the forecast amount, although this deviation should be redressed in 2021.

Different projects are underway in Latin America that have been affected by restrictions on freedom of movement and by delays in the supply chain, although the majority of the time lost is expected to be made up over the remainder of the year (see note 7).

- Activity has now resumed in Spain and is expected to fully recover in Latin America; as already mentioned, the Group's operations were not halted to any great extent during the state of emergency, and it has therefore not been necessary to resort to furlough measures (see note 16).
- Moreover, considering the Group's liquidity position, it has not been necessary to resort to the financial aid offered by the different authorities (see note 12).
- In the first half of the year, the Group incurred extraordinary expenditure due to contributions made to the healthcare authorities for the purchase of healthcare supplies to fight the pandemic, and to purchases of personal protective equipment and for additional cleaning of workplaces. At 30 June these expenses amount to approximately Euros 3 million (see note 16).
- Regarding the analysis of the recoverability of assets, the Group has reviewed the estimates calculated at the 2019 year end, considering the main variables and assumptions used and whether these have changed as a result of COVID-19 and/or business performance, concluding that no indications of impairment have been identified within the Group at 30 June 2020.

However, depending on future developments in economic recovery in the different sectors and countries in which the Group operates, and the impact of such trends on its activities, certain scenarios could emerge that may require impairment to be recognised.



The Group's management and directors will continue to assess the situation and closely monitor any incidents arising in the essential infrastructure it manages, as well as trends in other external factors and the impact such factors could have on the financial statements.

## 6. Business Combinations

---

### Business combinations carried out in 2019

- **Acquisition of Hispasat, S.A.**

On 12 February 2019 Red Eléctrica Corporación, S.A. announced the agreement reached with Abertis Infraestructuras, S.A. (hereinafter Abertis) for Red Eléctrica Corporación, through Red Eléctrica Sistemas de Telecomunicaciones, S.A.U. (hereinafter RESTEL), a wholly owned subsidiary of Red Eléctrica Corporación, S.A., to acquire an 89.68% interest in Hispasat, S.A. (hereinafter Hispasat) from Abertis. The purchase price for 89.68% of the share capital of Hispasat was Euros 933 million. In accordance with applicable legislation, the parties sought the pertinent authorisation for the transaction, this being one of the conditions precedent for the agreement signed by the two parties to come into effect. The transaction payment was made and the Red Eléctrica Group assumed control of Hispasat on 3 October 2019, once the conditions precedent had been fulfilled.

The acquiree's statutory and principal activity consists of the operation of satellite telecommunications systems.

The business combination was recognised provisionally in 2019, as indicated in note 5 to the consolidated annual accounts for that year. After completing the purchase price allocation (PPA) in 2020, the Group recognised the measurement period adjustments as if they had been known at the acquisition date, i.e. 3 October 2019, and restated the comparative figures for the prior year. In any case, the adjustments only include information relating to events and circumstances that existed at the acquisition date.

At the acquisition date the Group recognised the assets acquired and liabilities assumed at their fair value as determined by an independent expert. The non-controlling interest in the acquiree was recognised in the amount of the percentage interest in the fair value of the net assets acquired, inasmuch as a non-controlling interest gives the holder a present entitlement to the economic benefits and the right to the proportionate share of the net assets of the acquiree in the event of liquidation.

The total cost of the business combination was Euros 933 million, reflecting the purchase price for 89.68% of the share capital of Hispasat, S.A. Goodwill was calculated as the difference between the purchase price and the share of the fair value of the identifiable assets and liabilities existing at the transaction date, i.e. Euros 228.1 million.



The table below summarises the net assets acquired at the acquisition date:

Thousands of Euros	03/10/2019	Adjustments	Fair value
Intangible assets	51,727	15,234	66,961
Property, plant and equipment	929,344		929,344
Other non-current assets	91,397	27,402	118,799
Other current assets	59,956	24,021	83,977
Cash and cash equivalents	29,911		29,911
<b>Total assets</b>	<b>1,162,335</b>	<b>66,657</b>	<b>1,228,992</b>
Non-current liabilities	(274,394)	(19,897)	(294,291)
Current liabilities	(118,957)	(29,061)	(148,018)
<b>Total liabilities</b>	<b>(393,351)</b>	<b>(48,958)</b>	<b>(442,309)</b>
Non-controlling interests	(79,359)	(2,396)	(81,755)
<b>Total net assets</b>	<b>689,625</b>	<b>15,303</b>	<b>704,928</b>
Price paid			933,000
Goodwill			228,072

As a result of the purchase price allocation, which was completed in the first half of 2020, at the date of the business combination the main fair value adjustments to the identifiable assets and liabilities of Hispasat are as follows:

- Recognition of an intangible asset amounting to Euros 15.2 million, reflecting the value of the “Hispasat” trademark. This intangible asset has a finite useful life of 10 years. The intangible asset representing the Hispasat trademark was essentially measured using the following methodology:
  - The businesses were measured using the income approach, and in particular using the discounted cash flow method, based on level 3 (i.e. unobservable) inputs.
  - The main measurement parameters used were as follows:
    - Discount rate for intangible assets: 8.5%
    - Royalty rate: 1%
  - The most sensitive assumptions included in the projections, which are based on sector forecasts and the analysis of Hispasat’s historical data, are trends in royalties for use of the assets by the licensees, operating and maintenance costs, and investments. In general terms the projections for the acquired businesses can be reasonably estimated on the basis of the agreements in place.
- Recognition of non-current and current assets amounting to Euros 51.4 million, mainly comprising the following:
  - Euros 23.7 million of deferred tax assets, primarily reflecting tax deductions available at the transaction date, based on the Group’s assessment of their future recoverability. These deferred tax assets are expected to be recovered within a period of no more than 15 years. In any case, most of the capitalised deductions would qualify for monetisation.
  - Euros 25.3 million of contingent assets as the balancing entry for the contingent liabilities arising from tax litigation in Brazil, which are guaranteed by the seller under the sale-purchase agreement.
  - Euros 3.7 million of deferred tax assets arising from the tax effect of fair value adjustments.



- Increase of Euros 13.6 million in financial liabilities, reflecting the difference between the estimated market value of financial debt and its carrying amount, of which Euros 9.8 million are non-current and Euros 3.8 million are current.
- Recognition of Euros 25.3 million under current liabilities, reflecting the contingent liabilities arising from tax litigation in Brazil related to the ICMS (Brazilian tax on the circulation of goods and services) as well as other taxes, mainly of an indirect nature, which have been contested and which are in turn guaranteed by Abertis under the sale-purchase agreement. As these contingencies are guaranteed by the seller, the corresponding indemnification asset has been recognised for the same amount.
- Euros 10.1 million of deferred tax liabilities arising from the tax effect of fair value adjustments.

The goodwill resulting from this business combination is attributable to the benefits and synergies expected to arise in the Red Eléctrica Group from the acquisition and integration of Hispasat. Goodwill amounts to Euros 228.1 million.

As already mentioned, in accordance with IFRS 3 Business Combinations, at 31 December 2019 the Group recognised the fair value adjustments provisionally. During 2020 the Group has completed the fair value measurement of the net assets of Hispasat, whereby it has identified additional adjustments to those previously recognised in the consolidated annual accounts at 31 December 2019. The Company has therefore restated the comparative information presented in the consolidated annual accounts for the year ended 31 December 2019. The main impacts on the consolidated annual accounts for the year ended 31 December 2019 of recognising the business combination at the acquisition date are as follows:

hundreds of Euros	31/12/2019 restated	31/12/2019	Variation	
Intangible assets	737,142	765,599	(28,457)	
Goodwill	231,724	275,034	(43,310)	(I)
Trademark	14,853	-	14,853	(II)
Deferred tax assets	66,009	44,307	21,702	(III)
<b>Total assets</b>	<b>12,655,205</b>	<b>12,661,960</b>	<b>(6,755)</b>	
Profit attributable to the Parent	714,752	718,040	(3,288)	(IV)
Non-controlling interests	72,641	98,630	(25,989)	(V)
<b>Total equity</b>	<b>3,585,157</b>	<b>3,614,434</b>	<b>(29,277)</b>	
Non-current loans and borrowings	5,267,323	5,258,474	8,849	(VI)
Current loans and borrowings	1,197,980	1,194,335	3,645	(VI)
Deferred tax liabilities	466,283	456,255	10,028	(VII)
<b>Total liabilities</b>	<b>9,070,047</b>	<b>9,047,526</b>	<b>22,521</b>	
<b>Total equity and liabilities</b>	<b>12,655,205</b>	<b>12,661,960</b>	<b>(6,755)</b>	

- (I) The variation in goodwill relates to the recognition of the business combination described above and to the recognition of goodwill in the amount of the percentage interest in the net assets acquired instead of the total amount which was recognised provisionally in 2019.
- (II) Trademark reflects the recognition of the aforementioned business combination, as well as the amortisation accumulated over the three months from the acquisition date to the 2019 year end, based on the useful life of the trademark.
- (III) The variation in deferred tax assets reflects the recognition of the tax credits related mainly to available tax deductions and deferred tax assets arising from the tax effect of the adjustments to the business combination.
- (IV) The variation in profit attributable to the Parent is mainly due to the recognition of amortisation of the trademark for the period from the acquisition date to the 2019 year end,



the decrease in borrowing costs for the same period, and the effect of the reduction in deferred tax assets.

- (V) Movement in non-controlling interests is primarily due to goodwill not being allocated and the impact of the measurement of the net assets allocated thereto.
- (VI) Movement in non-current and current loans and borrowings reflects the recognition of the business combination described above, as well as changes therein during the period from the acquisition date to the 2019 year end.
- (VII) Changes in deferred tax liabilities reflect the recognition of the business combination described above and movement therein from the acquisition date to the 2019 year end.

## 7. Intangible Assets, Property, Plant and Equipment and Investment Property

---

Additions to intangible assets, property, plant and equipment and investment property, without considering the assets arising on the application of IFRS 16, totalled Euros 193 million in the first half of 2020. Asset additions during this half of the year due to the application of IFRS 16 amount to Euros 1,983 thousand.

Depreciation and amortisation in the six-month period ended 30 June 2020 amounted to Euros 271,679 thousand (Euros 246,757 thousand in the six-month period ended 30 June 2019).

Operating expenses capitalised in the first half of 2020 totalled Euros 26,713 thousand (Euros 25,663 thousand in the first half of 2019).

Borrowing costs capitalised in the first half of 2020 amounted to Euros 3,933 thousand (Euros 3,485 thousand in the first half of 2019).

At 30 June 2020 intangible assets primarily comprise:

- Euros 232 million of goodwill arising from the business combinations of the Hispasat Group and CCNCM carried out in 2019.
- Euros 391 million, net of accumulated amortisation, mainly reflecting the concessions of the Peruvian companies TESUR, TESUR2, TESUR3, TESUR4 and CCNCM. The concession facilities of TESUR4 are under construction.
- Euros 14 million for the valuation of the HISPASAT trademark (see note 6).
- Euros 42 million of Hispasat's different bandwidth licences for the use of orbital slots above Brazilian territory.
- Euros 50 million for REDENOR 2's perpetual right to regulated tariffs (asset with indefinite useful life).

In respect of property, plant and equipment, in 2020 the Group has conducted a study on the useful life of transmission assets that came into service before 1998, due to the new remuneration model. This study was based on internal and external sources and demonstrated that, if certain operating conditions and appropriate operating and maintenance programmes were upheld, these facilities may have a longer useful life than that initially determined, ensuring security of operations in accordance with legal requirements. Consequently, depreciation and amortisation in the consolidated income statement at June 2020 include the impact of this change in estimate from 1 January 2020 onwards, which has entailed a reduction in the depreciation charge of approximately Euros 25 million at 30 June 2020 (a Euros 50 million reduction in depreciation at the 2020 year end). The average remaining useful life of these assets is now 14 years.



There have been no significant suspensions of facilities under construction during the period (see note 5).

Investment property has maintained a market value of around Euros 2 million.

There have been no additions, disposals or significant changes to the contractual lease terms reflected in the 2019 consolidated annual accounts.

As disclosed in note 6 to the 2019 consolidated annual accounts, at the reporting date for that year the Group tested intangible assets for impairment by calculating the value in use of the CGUs associated with the assets, which exceeds their carrying amount. The calculation was performed using discounted cash flows based on financial projections used by the Group. The discount rate applied was the weighted average cost of capital, taking into account the country risk premium.

At 30 June 2020, in light of the COVID-19 crisis, the Group has analysed its non-financial assets for possible indications of impairment. This analysis did not bring to light any indications of impairment in the Spanish or international electricity transmission businesses or in the telecommunications business at 30 June 2020, given that no significant incidents have arisen and operations have continued as normal. However, depending on future developments in economic recovery in the different sectors and countries in which the Group operates, and the impact of such trends on its activities, this analysis should be continually monitored.

At 30 June 2020 net assets (assets minus liabilities) do not exceed the market capitalisation of the Group.

## 8. Equity-accounted Investees

Movement in equity-accounted investees during the period is as follows:

Thousands of Euros	31.12.2019	Changes in the consolidated Group	Profit attributable to investment	Translation differences	Valuation adjustments	30.06.2020
Transmisora Eléctrica del Norte S.A. (TEN)	199,026	-	2,490	(2,490)	(6,874)	192,152
Hisodesat Servicios Estratégicos, S.A.	60,449	-	829	-	-	61,278
Grupo de Navegación Sistemas y Servicios, S.L.	119	-	-	-	-	119
Argo Energia Empreendimentos e Participações S.A.	-	374,262	4,688	(95,858)	-	283,093
<b>Total</b>	<b>259,594</b>	<b>374,262</b>	<b>8,007</b>	<b>(98,348)</b>	<b>(6,874)</b>	<b>536,642</b>

On 25 March 2020 the Brazilian company "Energia Empreendimentos e Participações S.A." (ARGO Energia), in which the Group holds a 50% interest through Red Eléctrica Brasil, was incorporated into the consolidated Red Eléctrica Group. This company is the parent of a group of electricity transmission concession operator companies in Brazil. As a joint venture, the Argo Group is incorporated into the financial statements of the Red Eléctrica Group using the equity method.



ARGO Energía holds three 30-year electricity transmission concessions in Brazil, encompassing 1,460 km of 500 kV and 230 kV lines and 11 substations, of which 1,150 km of lines and five substations have been operating since October 2019.

The acquisition cost was BRL 1,678.2 million (Euros 374.3 million) and the main financial indicators at the acquisition date are as follows:

(amounts in thousands)	Brazilian Reais	Euros
Non-current assets	4,336,659	789,661
Current assets	660,194	120,215
<b>TOTAL ASSETS</b>	<b>4,996,853</b>	<b>909,875</b>
Non-current liabilities	3,602,395	655,959
Current liabilities	324,101	59,015
<b>TOTAL LIABILITIES</b>	<b>3,926,496</b>	<b>714,974</b>
<b>TOTAL NET ASSETS</b>	<b>1,070,357</b>	<b>194,901</b>

<b>Gross operating profit</b>	<b>46,086</b>	<b>8,392</b>
<b>Loss after tax</b>	<b>(41,033)</b>	<b>(7,472)</b>

At 30 June 2020 the purchase price allocation (PPA) is preliminary and a provisional implicit gain of Euros 277 million has yet to be allocated.

## 9. Inventories

Details of inventories at 30 June 2020 and 31 December 2019 are as follows:

Thousands of Euros	30.06.2020	31.12.2019
Inventories	77,156	76,124
Write-downs	(33,173)	(33,404)
<b>Total</b>	<b>43,983</b>	<b>42,720</b>

Inventories primarily comprise the equipment, materials and spare parts used in the maintenance of electricity transmission facilities.

The Group performs periodic analysis to calculate the write-downs to be recognised in the consolidated income statement based on assumptions of turnover and consumption. The COVID-19 crisis has not had a significant impact.

## 10. Trade and Other Receivables

Details of trade and other receivables at 30 June 2020 and 31 December 2019 are as follows:

Thousands of Euros	30.06.2020	31.12.2019
Trade receivables	66,084	74,396
Other receivables	1,234,321	1,261,607
Current tax assets	3,707	10,004
<b>Total</b>	<b>1,304,112</b>	<b>1,346,007</b>



Other receivables mostly reflect amounts pending collection for regulated transmission and system operation activities performed in Spain.

The Group has not received any notice from customers concerning a breach of their contract as a whole, in relation to the COVID-19 crisis. Only one case has been identified, in the telecommunications business, linked to the air mobility sector where, given the temporary restrictions on air traffic, a customer has requested that the contract be temporarily amended. The impact of this adjustment is not significant to the Group.

At 30 June 2020 no trade receivables impacted by the COVID-19 crisis have been identified, other than those cases in which the customer's financial situation was already affected and provision has had to be made for the receivables, given the risk of default. The amount provided for is not significant.

Fair value estimates reflect the assumptions of market participants based on the information available and market conditions at the estimation date, and incorporate any risk premiums related to the COVID-19 crisis.

## 11. Equity

### a) Capital risk management

The Group's capital management is aimed at safeguarding its capacity to continue operating as a going concern, so as to provide shareholder remuneration while maintaining an optimum capital structure to reduce the cost of capital.

To maintain and adjust the capital structure, the Group can adjust the amount of dividends payable to shareholders, reimburse capital or issue shares.

The Group controls its capital structure on a gearing ratio basis, in line with sector practice. This ratio is calculated as net financial debt divided by the sum of the Group's equity and net financial debt. Net financial debt is calculated as follows:

Thousands of Euros	30.06.2020	31.12.2019 (*)
Non-current debt (**)	6,518,811	5,266,689
Current debt (**)	344,761	1,128,516
Foreign currency derivatives	(29,282)	(28,566)
Cash and cash equivalents	(568,116)	(328,570)
<b>Net financial debt (A)</b>	<b>6,266,174</b>	<b>6,038,069</b>
Equity (B)	3,399,175	3,585,156
<b>Gearing ratio = A/(A+B)</b>	<b>64.8%</b>	<b>62.7%</b>

(\*) Figures restated as a result of the recognition of the Hispasat business combination, effective 3 October 2019 (see notes 2.f and 6).

(\*\*) In both 2020 and 2019 interest payable has been excluded.

During the first half of 2020 the rating agency Standard & Poor's issued a new report, maintaining the Company's long-term rating of 'A-' and short-term rating of 'A-2', with a stable outlook. The rating agency Fitch Ratings maintained the long-term rating of 'A-' and short-term rating of 'F2', with a stable outlook.





## Equity attributable to the Parent

- **Capital and reserves**

- **Share capital**

At 30 June 2020 the Company's share capital is divided into 541,080,000 shares each represented by book entries, all subscribed and fully paid-in, and carrying the same voting and profit-sharing rights (notwithstanding the limits stipulated in the following paragraph). The shares are quoted on the four Spanish stock exchanges and traded through the SIBE (Spanish Stock Exchange Interlinking System).

The Company is subject to the shareholder limitations stipulated in the twenty-third additional provision of Law 54/1997 of 27 November 1997 and article 30 of Electricity Industry Law 24/2013 of 26 December 2013.

Pursuant to this legislation, any individual or entity may hold investments in the Company, provided that the sum of their direct or indirect interests in its share capital does not exceed 5% and their voting rights do not surpass 3%. These shares may not be syndicated for any purpose. Voting rights at the Parent are limited to 1% in the case of entities that carry out activities in the electricity sector, and individuals and entities that hold direct or indirect interests exceeding 5% of the share capital of such companies, without prejudice to the limitations for generators and suppliers set forth in article 30 of Electricity Industry Law 24/2013 of 26 December 2013. The shareholder limitations with regard to the Parent's share capital are not applicable to Sociedad Estatal de Participaciones Industriales (SEPI), which in any event will continue to hold an interest of no less than 10%. At 30 June 2020 and 31 December 2019 SEPI holds a 20% interest in the Company's share capital.

### **Reserves**

This item comprises the following:

- **Legal reserve**

Spanish companies are obliged to transfer 10% of the profits for the year to a legal reserve until such reserve reaches an amount equal to 20% of the share capital. This reserve is not distributable to shareholders and may only be used to offset losses if no other reserves are available. Under certain circumstances, it may also be used to increase share capital. At 30 June 2020 the legal reserve amounts to Euros 54,199 thousand, which exceeds 20% of share capital.

- **Other reserves**

This heading includes voluntary reserves of the Parent, reserves in consolidated companies and first-time application reserves, all of which are freely distributable. At 30 June 2020 these reserves amount to Euros 2,856,279 thousand.

- **Own shares**

At 30 June 2020 the Parent holds 2,358,826 own shares representing 0.4% of its share capital, with a total par value of Euros 1,179 thousand and an average acquisition price of Euros 17.53 per share.

These shares have been recognised as a reduction in the Group's equity in an amount of Euros 41,355 thousand at 30 June 2020.

The Parent has complied with the requirements of article 509 of the Spanish Companies Act, which provides that the par value of acquired shares listed on official secondary markets, together with those already held by the Parent and its subsidiaries, must not exceed 10% of the share capital. The subsidiaries do not hold own shares or shares in the Parent.

- **Profit/loss attributable to the Parent**

Profit for 2020 totals Euros 331,707 thousand (Euros 362,199 thousand at 30 June 2019).



## ○ Interim dividends and proposed distribution of dividends by the Parent

Dividends paid in the first half of 2020 and 2019, in thousands of Euros, are as follows:

Thousands of Euros	30.06.2020			30.06.2019		
	% of par value	Euros per share	Amount	% of par value	Euros per share	Amount
Ordinary shares	54.54%	0.2727	147,002	54.54%	0.2727	147,250
<b>Total dividends paid</b>	<b>54.54%</b>	<b>0.2727</b>	<b>147,002</b>	<b>54.54%</b>	<b>0.2727</b>	<b>147,250</b>
<b>Dividends charged to profit</b>	<b>54.54%</b>	<b>0.2727</b>	<b>147,002</b>	<b>54.54%</b>	<b>0.2727</b>	<b>147,250</b>

At their general meeting held on 14 May 2020, the shareholders approved the supplementary dividend for 2019 of Euros 0.7792 per share, resulting in a total gross dividend of Euros 1.0519 per share for that year. The supplementary dividend was paid on 1 July 2020.

### ● Valuation adjustments

This item essentially comprises the changes in financial assets at fair value through other comprehensive income stemming from equity instruments, hedging derivatives and translation differences deriving from subsidiaries with a different functional currency to that of the Group.

At 30 June 2020 this item has a negative balance of Euros 141,135 thousand, primarily reflecting negative valuation adjustments to hedges and translation differences due to the depreciation of the Brazilian Real, partly offset by positive valuation adjustments to financial assets at fair value through other comprehensive income arising from fluctuations in the listed share price of the Portuguese company REN.

### b) Non-controlling interests

Non-controlling interests under equity in the accompanying consolidated statement of financial position amount to Euros 68,940 thousand at 30 June 2020 and reflect the non-controlling interests in Hispasat Group companies and the Chilean company REDENOR. The amount recognised at 31 December 2019 has been restated following the completion of the Hispasat PPA (see note 6).

## 12. Financial Risk Management Policy

The Group's finance management is responsible for managing financial risk, ensuring consistency with the Group's strategy and coordinating risk management across the various Group companies, by identifying the main financial risks and defining the initiatives to be taken, based on different financial scenarios.

The methodology for identifying, measuring, monitoring and controlling risk, as well as the management indicators and measurement and control tools specific to each risk, follow the guidelines and criteria laid down in the Comprehensive Risk Management Policy and the Financial-Economic Policy.

At 30 June 2020, there have been no significant changes in the financial risk management policy since the previous reporting date. In 2020 there have been no major changes in the business or economic circumstances that affect the fair value of the Group's financial assets and financial liabilities.

The Group has continued to apply the risk management policies disclosed in note 17 to the consolidated annual accounts for 2019. However, as a result of the COVID-19 health crisis a contingency plan was launched with the primary objectives of protecting employee health, guaranteeing electricity supply and connections through telecommunication assets at all times, and preserving the Group's liquidity.

In this respect, details of the financial risks to which the Group is exposed, as well as the effect of the health crisis thereon, are as follows:



## Liquidity risk

The Group has a robust financial position which has been further strengthened to tackle the COVID-19 health crisis. Liquidity has been bolstered through the issue of new bonds in the first half of 2020, amounting to Euros 1,100 million (see note 13).

At 30 June 2020 the Group has credit facilities with undrawn amounts totalling Euros 1,955 million (Euros 1,669 million non-current and Euros 285 million current). Following these transactions, the Group's liquidity position ensures it will be able to meet operating cash flow requirements, honour debt maturities in 2020, 2021 and 2022, and address any adverse situations that might arise in the financial markets in the coming months as a result of the current crisis. Thanks to its solid financial position, the Group has not had to request state aid to alleviate the economic effects of the COVID-19 crisis.

The Group's financial debt at 30 June 2020 has an average maturity of 5.6 years (5.2 years at 31 December 2019). Payments of matured debt have totalled Euros 1,100 million in 2020 and there have been no debt renegotiations, defaults or non-compliance in respect of the financing instruments recognised, nor are any covenants expected to be breached at the reporting date.

## Market risk

Market risk reflects variations in the financial markets in terms of prices, interest and exchange rates, credit conditions and other variables that could affect short-, medium- and long-term finance costs.

Market risk is managed on the borrowings to be arranged (the currency, maturity and interest rates), and through the use of hedging instruments that allow the financial structure to be modified. Market risk specifically includes:

- **Interest rate risk**

At 30 June 2020, the Group has a low-risk debt structure with moderate exposure to fluctuations in interest rates. As a result of the debt policy implemented, which aims to bring the cost of debt into line with the financial rate of return applied to the Group's regulated assets, among other objectives, 83% of the Group's borrowings have been arranged at fixed rates, whilst the remaining financial debt is subject to variable rates.

Following the issues in 2020 and the new loan and credit transactions arranged, the overall average cost of financial debt has fallen slightly to 1.93% at 30 June 2020 (2.29% at 31 December 2019).

The interest rate risk to which the Group is exposed at 30 June 2020 and 31 December 2019 derives from changes in the fair value of derivative financial instruments and mostly affects equity, but not consolidated profit for the period. A sensitivity analysis of this risk is as follows (in thousands of Euros):

Thousands of Euros	Effect on consolidated equity of market interest rate fluctuations			
	2020		2019	
	+0.10%	-0.10%	+0.10%	-0.10%
<b>Interest rate hedges:</b>				
- Cash flow hedges. Interest rate swap	4,784	(4,825)	4,895	(4,940)
<b>Interest rate and exchange rate hedges:</b>				
- Cash flow hedges. Cross-currency swap	(88)	88	135	(137)

A 0.10% rise or decline in interest rates would have decreased or increased, respectively, consolidated profit by Euros 1,036 thousand at 30 June 2020.



The fair value sensitivity has been estimated using a valuation technique based on discounting future cash flows at prevailing market rates at 30 June 2020 and 31 December 2019.

At 30 June 2020 all hedges are effective and the forecast transactions designated as hedged items in cash flow hedges are still highly probable.

- **Currency risk**

Currency risk management considers transaction risk, arising on cash inflows and outflows in currencies other than the Euro, and translation risk, i.e. a company's exposure when consolidating its subsidiaries and/or assets located in countries whose functional currency is not the Euro.

With a view to reducing the currency risk on issues in the US private placements (USPP) market, the Group has arranged cash flow hedges through US Dollar/Euro cross-currency swaps on the principal and interest, which cover the amount and total term of the issue up to October 2035.

In order to mitigate translation risk on assets located in countries whose functional currency is not the Euro, the Group finances a portion of such investments in the functional currency. The Group has also arranged hedges of net investments in US Dollars using cross-currency swaps up to January 2021. Consequently, had the US Dollar and Brazilian Real simultaneously strengthened or weakened by 10% against the Euro at the reporting date, equity attributable to the Parent would have increased or decreased, respectively, by approximately Euros 33 million at 30 June 2020 (Euros 14 million at 31 December 2019).

Since the start of the COVID-19 crisis, the US Dollar has been the main safe haven for the global economy. Latin American currencies have lost value due to the flight of capital to safer regions and the worsening economic outlook. Brazil, Chile and Peru, where the Group has investments, are among the countries most affected by currency devaluation.

At 30 June 2020 the effect of these exchange rate fluctuations has resulted in exchange losses of Euros 2,885 thousand being recognised in the income statement. In addition, the Group's equity has diminished by Euros 82,052 thousand due to lesser exchange differences (see note 11).

- **Credit risk**

In light of the nature of revenues from electricity transmission and electricity system operation, and the solvency of the electricity system agents, the Red Eléctrica Group's principal activities are not significantly exposed to credit risk. For the Group's other activities, credit risk is mainly managed through instruments to reduce or limit such risk.

In any event, credit risk is managed through policies that contain certain requirements regarding counterparty credit quality, and further guarantees are requested when necessary.

At the reporting date the Group's exposure to credit risk in connection with the fair value of its derivatives is insignificant, having entered into collateral assignment agreements entailing collateral swaps with various counterparties since 2015 in order to mitigate this risk.

At 30 June 2020, less than 1% of balances are past due (less than 1% in 2019), and the companies do not consider there to be any risk as regards recoverability. The credit quality of the receivables is considered to be high.

### **Price risk**

The Group is exposed to price risk relating to equity instruments classified as financial assets at fair value through other comprehensive income in the consolidated statement of financial position. Equity investments on quoted markets basically comprise the 5% interest held by the Group in REN.

At 30 June 2020 REN's share price is down 10.7% compared to 31 December 2019, although the decline in the Portuguese stock market (PSI20) has been worse.



At 30 June 2020 had the listed share price of the Portuguese company REN been 10% higher or lower, equity would have increased or decreased, respectively, by approximately Euros 6 million (Euros 7 million in 2019).

### 13. Financial Assets, Financial Liabilities and Derivatives

#### a) Financial assets

Details of the Red Eléctrica Group's current and non-current financial assets at 30 June 2020 and 31 December 2019, in thousands of Euros, are as follows:

Thousands of Euros	30.06.2020				
	At fair value through other comprehensive income	At fair value through profit or loss	At amortised cost	Hedging derivatives	Total
Equity instruments	84,972	-	-	-	84,972
Derivatives	-	-	-	22,417	22,417
Other financial assets	-	6,209	30,817	-	37,026
<b>Non-current</b>	<b>84,972</b>	<b>6,209</b>	<b>30,817</b>	<b>22,417</b>	<b>144,415</b>
Other financial assets	-	-	28,288	-	28,288
Derivatives	-	-	-	18,012	18,012
<b>Current</b>	<b>-</b>	<b>-</b>	<b>28,288</b>	<b>18,012</b>	<b>46,300</b>
<b>Total</b>	<b>84,972</b>	<b>6,209</b>	<b>59,105</b>	<b>40,429</b>	<b>190,715</b>

Thousands of Euros	31.12.2019				
	At fair value through other comprehensive income	At fair value through profit or loss	At amortised cost	Hedging derivatives	Total
Equity instruments	91,206	-	-	-	91,206
Derivatives	-	-	-	14,732	14,732
Other financial assets	-	2,542	18,823	-	21,365
<b>Non-current</b>	<b>91,206</b>	<b>2,542</b>	<b>18,823</b>	<b>14,732</b>	<b>127,303</b>
Other financial assets	-	-	58,200	-	58,200
Derivatives	-	-	-	11,311	11,311
<b>Current</b>	<b>-</b>	<b>-</b>	<b>58,200</b>	<b>11,311</b>	<b>69,511</b>
<b>Total</b>	<b>91,206</b>	<b>2,542</b>	<b>77,023</b>	<b>26,043</b>	<b>196,814</b>

Equity instruments essentially comprise the 5% interest held by the Parent in REN, a holding company that encompasses the operation and use of electricity transmission assets and various gas infrastructure in Portugal. At 30 June 2020 this investment amounts to Euros 81,731 thousand.

This interest was acquired in 2007 for Euros 98,822 thousand. The value of this investment is subject to the listed share price. In 2020 the value of this investment has declined and the corresponding valuation adjustment has been recognised directly in the Group's equity.

Other financial assets at fair value through profit or loss include the investment in economic interest groups (EIGs). These EIGs engage in the lease of assets operated by an unrelated party, which retains



most of the risks and rewards of the activity, while the Group only avails of the tax benefits pursuant to Spanish legislation. The Group recognises the tax losses incurred by these EIGs against the investments, together with the corresponding finance income reflecting the difference compared to income tax payable to the taxation authorities.

Other financial assets at amortised cost primarily include the Euros 19,068 thousand loan extended to TEN under non-current, and loans to third parties amounting to Euros 8,335 thousand under current. The remaining amount of other financial assets at amortised cost mainly comprises deposits and guarantees, both current and non-current.

Details of the Group's financial assets measured at fair value using the inputs defined for this calculation at 30 June 2020 and 31 December 2019 are as follows:

Thousands of Euros	30.06.2020			
	Level 1	Level 2	Level 3	Total balance
Equity instruments	81,731	-	3,241	84,972
Derivatives	-	40,429	-	40,429
Other financial assets	-	6,209	-	6,209

Thousands of Euros	31.12.2019			
	Level 1	Level 2	Level 3	Total balance
Equity instruments	90,738	-	468	91,206
Derivatives	-	26,043	-	26,043
Other financial assets	-	2,542	-	2,542

Level 1 equity instruments reflect the interest held in REN. Level 2 essentially comprises foreign currency and interest rate derivatives.

#### b) Financial liabilities

Details of the Red Eléctrica Group's current and non-current financial liabilities at 30 June 2020, in thousands of Euros, are as follows:

Thousands of Euros	30.06.2020		
	Financial liabilities	Hedging derivatives	Total
Loans and borrowings	2,722,326	-	2,722,326
Bonds and other marketable securities	3,796,956	-	3,796,956
Derivatives	-	39,658	39,658
Other financial liabilities <sup>(1)</sup>	58,937	-	58,937
<b>Non-current</b>	<b>6,578,219</b>	<b>39,658</b>	<b>6,617,877</b>
Loans and borrowings	170,907	-	170,907
Bonds and other marketable securities	209,797	-	209,797
Derivatives	-	2,058	2,058
Other financial liabilities	806,924	-	806,924
<b>Current</b>	<b>1,187,628</b>	<b>2,058</b>	<b>1,189,686</b>
<b>Total</b>	<b>7,765,847</b>	<b>41,716</b>	<b>7,807,563</b>



Thousands of Euros	31.12.2019 (*)		
	Financial liabilities	Hedging derivatives	Total
Loans and borrowings	2,554,203	-	2,554,203
Bonds and other marketable securities	2,713,120	-	2,713,120
Derivatives	-	48,266	48,266
Other financial liabilities	60,286	-	60,286
<b>Non-current</b>	<b>5,327,609</b>	<b>48,266</b>	<b>5,375,875</b>
Loans and borrowings	224,851	-	224,851
Bonds and other marketable securities	973,129	-	973,129
Derivatives	-	4,996	4,996
Other financial liabilities	648,557	-	648,557
<b>Current</b>	<b>1,846,537</b>	<b>4,996</b>	<b>1,851,533</b>
<b>Total</b>	<b>7,174,146</b>	<b>53,262</b>	<b>7,227,408</b>

(\*) Figures restated as a result of the recognition of the Hispasat business combination, effective 3 October 2019 (see notes 2.f and 6). Loans and borrowings include an additional Euros 8,849 thousand under non-current and Euros 3,645 thousand under current.

(1) Mainly reflects non-current payables to suppliers of fixed assets and non-current lease payables.

Loans and borrowings and bonds and other marketable securities include both the principal and the accrued interest payable at the dates indicated.

The carrying amount and fair value of loans and borrowings and bonds and other marketable securities, excluding the accrued interest payable, at 30 June 2020 and 31 December 2019 are as follows:

Thousands of Euros	Carrying amount		Fair value	
	30.06.2020	31.12.2019 (*)	30.06.2020	31.12.2019
Issues in Euros	3,435,906	3,086,602	3,646,306	3,310,737
Issues in US Dollars	516,882	544,496	673,683	653,965
Bank borrowings in Euros	2,514,354	2,413,795	2,524,946	2,441,959
Bank borrowings in foreign currency	367,148	350,312	383,838	367,612
<b>Total</b>	<b>6,834,290</b>	<b>6,395,205</b>	<b>7,228,773</b>	<b>6,774,273</b>

(\*) Figures restated as a result of the recognition of the Hispasat business combination, effective 3 October 2019 (see notes 2.f and 6). Bank borrowings in Euros include an additional Euros 12,494 thousand.



Movement in issues, repurchases or redemptions of debt securities in the six-month periods ended 30 June 2020 and 2019, expressed in thousands of Euros, is as follows:

Thousands of Euros	30.06.2020				
	Opening outstanding balance at 31.12.2019	Issues	(-) Repurchases or redemptions	(+/-) Exchange rate and other adjustments	Closing outstanding balance at 30.06.2020
Debt securities issued in an EU member state requiring a prospectus to be filed	3,086,602	1,200,014	(845,100)	(5,610)	3,435,906
Debt securities issued in an EU member state not requiring a prospectus to be filed	-	-	-	-	-
Other debt securities issued outside EU member states	544,496	-	(2,261)	3,929	546,164
<b>Total</b>	<b>3,631,098</b>	<b>1,200,014</b>	<b>(847,361)</b>	<b>(1,681)</b>	<b>3,982,070</b>

Thousands of Euros	30.06.2019				
	Opening outstanding balance at 31.12.2018	Issues	(-) Repurchases or redemptions	(+/-) Exchange rate and other adjustments	Closing outstanding balance at 30.06.2019
Debt securities issued in an EU member state requiring a prospectus to be filed	3,144,659	513,035	(530,597)	5,376	3,132,473
Debt securities issued in an EU member state not requiring a prospectus to be filed	-	-	-	-	-
Other debt securities issued outside EU member states	458,748	986	(1,979)	4,459	462,214
<b>Total</b>	<b>3,603,407</b>	<b>514,021</b>	<b>(532,576)</b>	<b>9,835</b>	<b>3,594,687</b>

The outstanding balance at 30 June 2020 and 2019 of debt securities requiring a prospectus to be filed relates to issues registered in Dublin and Luxembourg.

At 30 June 2020 issues essentially comprise two debt issues under the Euro Medium Term Note (EMTN) Programme in the Euromarket amounting to Euros 700 million and Euros 400 million, respectively, and promissory notes amounting to Euros 100 million issued in the Euromarket through Red Eléctrica Financiaciones and maturing in the short term, of which Euros 295 million have been redeemed during the period.

Repurchases or redemptions at 30 June 2020 reflect the redemption of Euros 550 million on maturity of Eurobonds issued in 2011, as well as the redemption of the above-mentioned promissory notes.

At 30 June 2020 the accrued interest payable on these issues amounts to Euros 36,415 thousand (Euros 26,906 thousand in the first half of 2019).





The fair value of all loans and borrowings and issues of bonds and other marketable securities has been estimated using valuation techniques based on discounting future cash flows at the market rates in force at each date.

Details of the Group's financial liabilities measured at fair value using the inputs defined for this calculation at 30 June 2020 and 31 December 2019 are as follows:

Thousands of Euros	30.06.2020			
	Level 1	Level 2	Level 3	Total balance
Derivatives	-	41,716	-	41,716

Thousands of Euros	31.12.2019			
	Level 1	Level 2	Level 3	Total balance
Derivatives	-	53,262	-	53,262

Level 2 comprises foreign currency and interest rate derivatives, which are recognised at fair value. There are no significant differences between the fair value and the carrying amount at 30 June 2020 and 31 December 2019. Liabilities at amortised cost are not disclosed by fair value hierarchy level.

The Group's fair value estimates reflect the assumptions of market participants based on the information available and market conditions at the date these financial statements were drawn up, incorporating, where appropriate, risk premiums arising from the increased uncertainty and other impacts caused by the COVID-19 crisis, adjusting the estimates for own and counterparty credit risk and taking into consideration the fact that unobservable inputs have become significant.

Moreover, assets and liabilities have been recognised at their acquisition-date fair value, and provisional amounts have only been adjusted for past events and circumstances existing at that date.

## 14. Trade and Other Payables

Details at 30 June 2020 and 31 December 2019 are as follows:

Thousands of Euros	30.06.2020	31.12.2019
Suppliers	283,181	311,879
Other payables	51,945	61,490
Current tax liabilities	67,321	23,574
<b>Total</b>	<b>402,447</b>	<b>396,943</b>

Suppliers essentially reflect payables arising from engineering, construction and maintenance work and modifications to electricity facilities, as well as balances pending settlement in relation to the Spanish electricity system for the activities carried out.

Other payables in 2020 and 2019 basically comprise balances vis-à-vis public entities, for the most part value added tax (VAT).

In 2020 and 2019 current tax liabilities reflect income tax payable.



## 15. Taxation

The tax group headed by Red Eléctrica Corporación, S.A. has filed consolidated tax returns in Spain since 2002. At 31 December 2019 the tax group included the Parent, REE, REI, REF, REINTEL, REINCAN, RESTEL and RETIT. In 2020 Hispasat, S.A. and Hispasat Canarias, S.L. have been added to the tax group headed by Red Eléctrica Corporación, S.A. In 2019 these companies filed consolidated tax returns in Spain as part of a group headed by Hispasat, S.A.

The balance of deferred taxes is as follows:

Thousands of Euros	30.06.2019	31.12.2019 (*)
Deferred tax assets	67,206	66,009
Deferred tax liabilities	(436,316)	(466,283)
<b>Total</b>	<b>(369,110)</b>	<b>(400,274)</b>

(\*) Following the recognition of the Hispasat business combination, the Group's deferred tax assets and liabilities have been restated by Euros 21,701 thousand and Euros -10,028 thousand, respectively (see note 6).

No significant movements were recorded in deferred tax assets and liabilities in the first half of 2020. At 30 June 2020 and 2019 deferred tax liabilities mainly arise from accelerated depreciation for tax purposes of certain fixed assets.

The Group does not consider there to be any additional tax risks or uncertainties derived from the COVID-19 crisis which would significantly affect the taxes recognised.

## 16. Income and Expenses

### a) Revenue

Details for the six-month periods ended 30 June 2020 and 2019, by geographical area, are as follows:

Thousands of Euros	30.06.2020	30.06.2019
Domestic market	913,574	961,739
International market	64,318	31,335
a) European Union	10,330	9,759
a.1) Eurozone	10,330	9,759
c) Other countries	53,988	21,576
<b>Total</b>	<b>977,892</b>	<b>993,074</b>

Domestic market essentially includes the revenue from transmission and electricity system operation services in Spain, which represents 84% of the Group's revenue at June 2020. This item also includes the revenue from telecommunications services rendered in Spain, which represents 10% of the Group's revenue at June 2020.

International markets primarily include revenue from reinsurance services, presented under European Union, and revenue from electricity transmission and telecommunications services rendered by the Group companies in Latin America, presented under other countries.

Both revenue from the performance obligations of transmission and system operation services and revenue from telecommunications services are recognised over time.



## b) Other operating income

This item mostly includes insurance payouts for accidents and breakdowns covered by the policies arranged, other non-trading income, and government operating grants taken to the income statement.

## c) Supplies and other operating expenses

Supplies and other operating expenses mainly comprise repair and maintenance costs incurred for technical electricity facilities and telecommunications networks, as well as IT and advisory services, leases, taxes and other services.

## d) Personnel expenses

Details for the six-month periods ended 30 June 2020 and 2019 are as follows:

Thousands of Euros	30.06.2020	30.06.2019
Salaries, wages and other remuneration	65,695	59,350
Social Security	15,007	13,318
Contributions to pension funds and similar obligations	1,181	1,017
Other items and employee benefits	5,600	3,338
<b>Total</b>	<b>87,483</b>	<b>77,023</b>

The Group has not applied for any furlough schemes (“ERTEs” per the Spanish acronym) or carried out any dismissals or personnel restructuring as a result of the COVID-19 crisis. Moreover, it has not changed any employee remuneration policies due to the crisis.

- **Employees**

The distribution by gender of the average workforce of the Parent and the Red Eléctrica Group for the six-month periods ended 30 June 2020 and 2019 is as follows:

	Red Eléctrica Group		Red Eléctrica Corporación S.A.	
	30.06.2020	30.06.2019	30.06.2020	30.06.2019
Male	1,518	1,362	1	2
Female	534	433	6	5
<b>Total</b>	<b>2,052</b>	<b>1,795</b>	<b>7</b>	<b>7</b>

The increase in the average headcount of the Group at 30 June 2020 compared with 2019 is mainly due to the addition of Hispasat personnel.

## e) Income tax

The tax rate was 24.6%, compared to 24.7% in the prior period.

## f) Extraordinary expenses resulting from the COVID-19 crisis

The Group has spent an additional Euros 3 million as a result of the pandemic triggered by COVID-19, mainly on donations and the acquisition of personal protective equipment.



## 17. Transactions with Equity-accounted Investees and Related Parties

Related party transactions are carried out under normal market conditions. Details in thousands of Euros are as follows:

Thousands of Euros	30.06.2020		
	Directors and management	Other related parties	Total
<b>Expenses and income:</b>			
Leases	-	-	-
Other expenses	-	77	77
<b>Total expenses</b>	-	<b>77</b>	<b>77</b>
Services rendered		83	83
Finance income	-	475	475
<b>Total income</b>	-	<b>558</b>	<b>558</b>
<b>Other transactions:</b>			
Financing agreements, loans and capital contributions (lender)	-	19,068	19,068
<b>Total other transactions</b>	-	<b>19,068</b>	<b>19,068</b>
<b>Closing balance:</b>			
Trade receivables		204	204
Loans and credit extended	-	19,068	19,068
<b>Total balances receivable</b>	-	<b>19,272</b>	<b>19,272</b>
Suppliers and trade payables	-	307	307
<b>Total balances payable</b>	-	<b>307</b>	<b>307</b>

Thousands of Euros	31.12.2019		
	Directors and management	Other related parties	Total
<b>Expenses and income:</b>			
Leases	-	83	83
Other expenses	-	485	485
<b>Total expenses</b>	-	<b>568</b>	<b>568</b>
Services rendered	-	374	374
Finance income	-	1,364	1,364
<b>Total income</b>	-	<b>1,738</b>	<b>1,738</b>
<b>Other transactions:</b>			
Financing agreements, loans and capital contributions (lender)	123	24,677	24,800
<b>Total other transactions</b>	<b>123</b>	<b>24,677</b>	<b>24,800</b>
<b>Closing balance:</b>			
Trade receivables	-	644	644
Loans and credit extended	123	24,677	24,800
<b>Total balances receivable</b>	<b>123</b>	<b>25,321</b>	<b>25,444</b>
Suppliers and trade payables	-	194	194
<b>Total balances payable</b>	-	<b>194</b>	<b>194</b>



At both 30 June 2020 and 31 December 2019, financing agreements, loans and capital contributions for which the Group acts as the lender vis-à-vis other related parties reflect the loan extended to the Group company TEN. Expenses, income and balances vis-à-vis other related parties mainly relate to the Group companies TEN and Hisdesat. Inasmuch as TEN and Hisdesat are accounted for using the equity method, these transactions are not eliminated on consolidation of the Group.

## 18. Remuneration of the Board of Directors

---

At the proposal of the board of directors and in accordance with the articles of association, the annual report on the remuneration of directors, which includes the remuneration of the board of directors for 2020, was approved by the shareholders at their general meeting on 14 May 2020.

The approved remuneration of the board of directors for 2020, including the remuneration of the board members, the chairwoman and the CEO, was unchanged vis-à-vis 2019.

The chairwoman receives fixed annual remuneration in respect of the non-executive chairwoman duties associated with this position, in addition to remuneration for being a member of the board of directors. The remuneration scheme for this position consists solely of fixed amounts, with no annual or multi-year variable remuneration and no termination benefit. In 2020 both remuneration components are under the same terms as in 2019.

At its meeting held on 28 January 2020, the board of directors took note of the irrevocable resignation tendered by Mr. Jordi Sevilla Segura from his position as a director, and therefore as non-executive chairman of the board of directors and of the Company.

Further, in its meeting held on 25 February 2020 the board of directors approved, inter alia, the appointment of Ms. Beatriz Corredor Sierra as a director of the Company, in the category of "other external directors", until the next general shareholders' meeting, and her appointment as non-executive chairwoman of the board of directors and of the Company.

Subsequently, at their general meeting held on 14 May 2020, the shareholders ratified the appointment of Ms. Beatriz Corredor Sierra as a director of the Company.

As regards Mr. Jordi Sevilla Segura, in accordance with his contract approved by the board of directors on 31 July 2018, he has not received any termination benefit as a result of the end of his legal and labour relations with the Company as chairman of the board of directors and of the Company.

The remuneration allocated to the CEO includes the fixed and variable annual and multi-year components corresponding to executive duties and the fixed remuneration for being a member of the board of directors. Employee benefits form part of the remuneration for this position. A portion of the annual variable remuneration is paid through the delivery of Company shares.

Moreover, the CEO has been included in a defined contribution benefit scheme. This scheme covers the retirement, death and permanent disability contingencies. Red Eléctrica's obligation is limited to an annual contribution equal to 20% of the CEO's fixed annual remuneration.

The annual variable remuneration of the CEO is set by the Appointments and Remuneration Committee of the Parent at the start of each year, using predetermined quantifiable and objective criteria. The targets are in line with the strategies and actions established in the Company's Strategic Plan and the degree of fulfilment is assessed by the Committee.

Pursuant to the remunerations policy and in line with standard market practices, the CEO's contract provides for a termination benefit equal to one year's salary in the event that labour relations are terminated due to dismissal or changes of control.

As regards the CEO, at its meeting held on 27 May 2019, the board of directors adopted, among others, the following agreements:

To dismiss Mr. Juan Francisco Lasala Bernad as CEO and to accept his resignation from the position of executive director of the Company.



To appoint Mr. Roberto García Merino as executive director and, subsequently, as CEO of the Company, until the following general shareholders' meeting.

In line with market practices in such cases, as a result of the appointment of the new CEO, the existing employment contract has been suspended. Should the employment contract be terminated, he would accrue the remuneration due at the date of suspension as an indemnity. For this purpose, his tenure at Red Eléctrica de España, S.A.U. up to the date he was appointed CEO (15 years), plus the period in which he rendered services – if any – following his termination as CEO, would be taken into consideration, in accordance with employment legislation in force. Both the economic regime and the suspension of the employment relationship of the new CEO are in line with those applied to the previous CEO.

In line with standard market practices, Mr. Juan Francisco Lasala Bernad was entitled to a settlement in respect of his labour relations and an indemnity as CEO equal to one year's salary in the event that labour relations were terminated due to dismissal or changes of control. The amount associated with his termination as CEO, which included the indemnity paid, was settled when his relationship with the Company was terminated.

The remuneration of the board of directors includes fixed annual remuneration, allowances for attending board meetings, remuneration for work on the board of directors' committees and specific annual remuneration both for the chairs of the committees and the coordinating independent director. The components and amounts of this remuneration have not changed in 2020.

Reasonable and duly supported expenses incurred as a result of their attendance at meetings and other tasks directly related to carrying out their duties, such as travel expenses, accommodation, meals and any other such costs that may be incurred, will also be paid or reimbursed to the directors.

The total amounts accrued by the members of the Parent's board of directors at 30 June 2020 and 2019 are as follows:

Thousands of Euros	30.06.2020	30.06.2019
Total remuneration of the board of directors	1,221	1,261
Remuneration of the board in respect of executive duties <sup>(1)</sup>	371	413
<b>Total</b>	<b>1,592</b>	<b>1,674</b>

<sup>(1)</sup> In 2019 this includes annual fixed and variable remuneration accrued during the year and does not include the indemnity amounting to Euros 818 thousand for the termination of the CEO that year.

The year-on-year decrease in total remuneration of the board of directors is mainly attributable to the fact that for a certain period during the first six months of 2020 there was no chair of the board, whereas in 2019 there was a chairman for the entire period.

The year-on-year decrease in remuneration of the board in respect of executive duties is because the amount accrued for the position of executive director was lower in 2020 than in 2019.

The remuneration accrued by the members of the Company's board of directors at 30 June 2020 and 2019, broken down by components, is as follows:

Thousands of Euros	30.06.2020	30.06.2019
Fixed remuneration	1,118	1,180
Variable remuneration	131	148
Allowances	108	108
Committee work <sup>(1)</sup>	170	168
Other remuneration	65	70
<b>Total <sup>(2)</sup></b>	<b>1,592</b>	<b>1,674</b>

(1) Includes the remuneration of the chairs of the committees and the coordinating independent director.

(2) Does not include the indemnity amounting to Euros 818 thousand for the termination of the CEO in 2019.



In addition to the foregoing, on 31 December the directors' remuneration scheme for 2014-2019, which encompassed the CEO, drew to a close. The amount paid to the CEO under this plan was Euros 355 thousand.

The aforementioned directors' remuneration plan having now closed, work is underway to design a new plan, which will be consistent with the Strategic Plan in force and is expected to be approved in the coming months.

At 30 June 2020 and 2019 no loans or advances have been granted to the members of the board of directors, nor have any guarantees been extended on their behalf. The Company has no pension or life insurance obligations with the members of the board of directors at those dates, other than those previously mentioned, nor have any loans or advances been extended to board members.

At 30 June 2020 and 2019 the Group has taken out public liability insurance to cover claims from third parties in respect of possible damage and loss caused by actions or omissions in performing duties as Group directors. These policies cover the Group's directors and senior management and the annual premiums amount to Euros 328 thousand, inclusive of tax, in 2020 (Euros 142 thousand at 31 December 2019). These premiums are calculated based on the nature of the Group's activity and its financial indicators, thus they cannot be broken down individually or allocated to directors and senior management separately.

In 2020 and 2019 the members of the board of directors did not engage in transactions with the Company or Group companies, either directly or through intermediaries, other than ordinary operations under market conditions.

## 19. Remuneration of Senior Management

Total remuneration accrued by senior management personnel up to 30 June 2020 amounted to Euros 329 thousand (Euros 332 thousand up to 30 June 2019) and is recognised as personnel expenses in the consolidated income statement. These amounts include the accrual of variable annual remuneration, on the assumption that the objectives set each year will be met. After the fulfilment of these objectives has been assessed, the variable remuneration, adjusted to the actual fulfilment rate, is paid in the first few months of the following year.

At 30 June 2020 and 2019, the senior management personnel who have rendered services for the Group are as follows:

Name	Position
Eva Pagán Díaz	General Manager of Transmission
Miguel Duvison García	General Manager of Operations

Euros 9 thousand of the total remuneration accrued by these senior managers consisted of contributions to life insurance and pension plans (Euros 9 thousand in 2019).

No advances or loans have been extended to these senior managers at 30 June 2020. At 30 June 2019 loans had been granted to these senior managers that have an outstanding balance of Euros 136 thousand. They fall due in 2024 and have the same conditions as those applied to loans granted to personnel under the collective bargaining agreement. The equivalent interest rate applicable to these loans is 0.76%.

On 31 December the directors' remuneration plan for 2014-2019 drew to a close. The amount paid to the senior management personnel included in this plan was Euros 665 thousand.

The aforementioned directors' remuneration plan having now closed, work is underway to design a new plan, which will be consistent with the Strategic Plan in force and is expected to be approved in the coming months.



The contracts in place with serving senior management personnel do not include guarantee or golden parachute clauses, in the event of dismissal. In the event the employment relationship were terminated, the indemnity to which senior management personnel would be entitled would be calculated in accordance with applicable legislation. The contracts for these executives have been approved by the Appointments and Remuneration Committee and the board of directors has received notice thereof.

Senior management personnel who rendered services in the Group as at 30 June 2020 are included in the Structural Management Plan implemented by the Company in 2015.

At 30 June 2020 and 2019 the Group has taken out public liability insurance to cover claims from third parties in respect of possible damage and loss caused by actions or omissions in performing duties as senior management of the Group. These policies cover all the Group's directors and senior management and the annual premiums amount to Euros 328 thousand, inclusive of tax, in 2020 (Euros 142 thousand in 2019). These premiums are calculated based on the nature of the Group's activity and its financial indicators, thus they cannot be broken down individually or allocated to directors and senior management separately.

## 20. Segment Reporting

---

The Red Eléctrica Group segments its business activities based on their nature, reflecting the main branches of activity used by the Group in its management and decision-making.

At 30 June 2020, the Group's operating segments and their main products, services and operations are as follows:

- **Management and operation of domestic electricity infrastructure:**

This segment comprises the Group's principal activity, as sole transmission agent and system operator for the Spanish electricity system (TSO). Its mission is to guarantee the security and continuity of the electricity supply at all times and manage high-voltage electricity transmission.

The Group engages in the high-voltage transmission of electricity, through REE. To this end, it manages the electricity transmission network infrastructure that connects the power plants to the consumer distribution points. As transmission network manager, REE is responsible for the development and expansion of the network, its maintenance, managing the transfer of electricity between external systems and the mainland, and guaranteeing third-party access to the transmission network under equal conditions.

In addition, REE operates the mainland Spanish electricity system and the non-mainland systems in the Canary Islands, Balearic Islands, Ceuta and Melilla, guaranteeing the security and continuity of the electricity supply at all times. Operation of the system encompasses the necessary activities to guarantee such security and continuity, as well as proper coordination between the generation system and transmission network, ensuring that the energy produced by generators is transmitted to the distribution networks with the requisite quality under applicable legislation.

- **Management and operation of international electricity infrastructure:**

This segment comprises activities related to international business development as a natural form of growth, mainly focused on the construction and operation of electricity transmission networks outside Spain; at 30 June 2020, in Peru, Chile and Brazil specifically.

- **Telecommunications (satellites and fibre optics):**

The telecommunications segment comprises the operation of satellite infrastructure in Spain, Portugal and South America, as well as the lease in Spain of a broad dark fibre backbone network, and technical sites and spaces for housing customers' telecommunications equipment. The main services rendered are the lease and concession of fibre optics, the lease of sites, maintenance of telecommunications and other facilities, and integrated telecommunications infrastructure solutions





(towers, fibre optics, technical spaces and electricity supply) for telecom operators to render mobile telephone voice and data services on high-speed train (AVE) lines, as well as the provision of satellite capacity and telecommunications services in the wholesale satellite internet services market. The Hispasat Group is only included in this segment from October 2019 onwards, the date on which control of this company was assumed.

The Group also carries out reinsurance activities and fosters innovation in electricity and telecommunications. These activities do not meet the quantitative thresholds to be presented separately. Inter-segment sales prices are established based on the normal commercial terms and conditions with unrelated third parties.

The key indicators of the operating segments identified are as follows:

### Business segments at 30 June 2020

	Management and operation of electricity infrastructure		Telecommunications (fibre optics and satellites)	Other, corporate and adjustments	Total
	Domestic	International	Total	Total	
Thousands of Euros					
Revenue	817,470	25,648	148,155	(13,381)	977,892
External customers	814,267	25,480	127,214	10,932	977,892
Inter-segment revenue	3,203	168	20,942	(24,313)	-
Investments in equity-accounted associates (similar activity)	-	7,178	829	-	8,007
Depreciation and amortisation	(190,544)	(8,762)	(71,307)	(1,065)	(271,679)
<b>Results from operating activities</b>	<b>445,894</b>	<b>17,239</b>	<b>42,823</b>	<b>3,308</b>	<b>509,264</b>
Interest income	115	8,114	68	399	8,697
Interest expense	(55,879)	(13,983)	(5,926)	430	(75,358)
Investments in equity-accounted associates	-	-	-	-	-
Income tax	(98,500)	(1,788)	(5,302)	(2,459)	(108,050)
<b>Profit of the Parent after tax</b>	<b>291,748</b>	<b>9,062</b>	<b>29,233</b>	<b>1,664</b>	<b>331,707</b>
<b>Segment assets</b>	<b>9,582,126</b>	<b>1,199,726</b>	<b>1,894,780</b>	<b>367,024</b>	<b>13,043,656</b>
Equity-accounted investees	-	475,245	61,397	0	536,642
<b>Segment liabilities</b>	<b>7,437,362</b>	<b>687,131</b>	<b>1,019,620</b>	<b>500,368</b>	<b>9,644,481</b>



## Business segments at 30 June 2019

Thousands of Euros	Management and operation of electricity infrastructure		Telecommunications (fibre optics)	Other, corporate and adjustments	Total
	Domestic	International	Total	Total	
Revenue	917,533	21,698	67,579	(13,736)	993,074
External customers	913,781	21,533	47,190	10,571	993,074
Inter-segment revenue	3,752	165	20,389	(24,307)	-
Investments in equity-accounted associates (similar activity)	-	3,639	-	-	3,639
Depreciation and amortisation	(231,475)	(4,449)	(11,331)	497	(246,757)
<b>Results from operating activities</b>	<b>484,866</b>	<b>11,388</b>	<b>40,190</b>	<b>8,263</b>	<b>544,707</b>
Interest income	32	6,638	1	(3)	6,667
Interest expense	(61,302)	(9,966)	(3,922)	4,185	(71,004)
Income tax	(105,541)	(931)	(9,067)	(3,146)	(118,685)
<b>Profit of the Parent after tax</b>	<b>318,058</b>	<b>7,535</b>	<b>27,201</b>	<b>9,405</b>	<b>362,199</b>
<b>Segment assets</b>	<b>9,563,463</b>	<b>708,076</b>	<b>512,413</b>	<b>596,177</b>	<b>11,380,129</b>
Equity-accounted investees	-	192,954	-	-	192,954
<b>Segment liabilities</b>	<b>7,481,483</b>	<b>509,599</b>	<b>303,299</b>	<b>(219,717)</b>	<b>8,074,663</b>

Details of revenue and non-current assets, by geographical area, are as follows:

Thousands of Euros		
Revenue	30-Jun-20	30-Jun-19
Spain	913,574	961,739
Other	64,318	31,335
<b>Total</b>	<b>977,892</b>	<b>993,074</b>

Thousands of Euros		
Fixed assets (*)	30-Jun-20	31-Dec-19
Spain	9,819,466	9,914,300
Other	1,060,549	751,398
<b>Total</b>	<b>10,880,015</b>	<b>10,665,697</b>

(\*) Excludes non-current investments, deferred tax assets, and non-current trade and other receivables.



## 21. Earnings per Share

---

Details of earnings per share in the first half of 2020 and 2019 are as follows:

	30.06.2020	30.06.2019
Profit attributable to the Parent (thousands of Euros)	331,707	362,199
Number of shares	541,080,000	541,080,000
Average number of own shares	2,180,092	1,298,014
Basic earnings per share (Euros)	0.62	0.67
Diluted earnings per share (Euros)	0.62	0.67

At 30 June 2020 and 2019 the Group has not conducted any operations that would result in any difference between basic earnings per share and diluted earnings per share.

## 22. Events after 30 June 2020

---

No significant events have occurred between the reporting date and the date on which these consolidated interim financial statements were authorised for issue.



## Appendix I: Details of equity investments at 30 June 2020

### Red Eléctrica Group Details of equity investments at 30 June 2020

- Company

- Registered office

- Principal activity

	2020	
	Percentage ownership (1)	
	Direct	Indirect
Red Eléctrica Corporación, S.A., Parent, incorporated in 1985. - Paseo Conde de los Gaitanes, 177. Alcobendas. Madrid. (Spain). - Management of the business group; rendering of assistance or support services to investees and operation of the property owned by the Company.		
<b>A) Fully consolidated subsidiaries</b>		
Red Eléctrica de España, S.A.U. (REE) - Paseo Conde de los Gaitanes, 177. Alcobendas. Madrid. (Spain). - Transmission, operation of the Spanish electricity system and management of the transmission network.	100%	-
Red Eléctrica Internacional, S.A.U. (REI) - Paseo Conde de los Gaitanes, 177. Alcobendas. Madrid. (Spain). - Acquisition and holding of international equity investments. Rendering of advisory, engineering and construction services. Performance of electricity activities outside the Spanish electricity system.	100%	-
Red Eléctrica Infraestructuras de Telecomunicación, S.A.U. (REINTEL) - Paseo Conde de los Gaitanes, 177. Alcobendas. Madrid. (Spain). - Rendering of advisory, engineering, construction and telecommunications services.	100%	-
Red Eléctrica Infraestructuras en Canarias, S.A.U (REINCAN) - Calle Juan de Quesada, 9. Las Palmas de Gran Canaria. (Spain). - Construction of energy storage facilities in non-mainland and isolated systems.	100%	-
Red Eléctrica de España Finance, B.V. (RBV) - Hoogoorddreef 15. Amsterdam (Netherlands). - Financing activities. Incorporated in 2003 in the Netherlands to issue debt to finance the Red Eléctrica Group.	100%	-
Red Eléctrica Financiaciones, S.A.U. (REF) - Paseo Conde de los Gaitanes, 177. Alcobendas. Madrid. (Spain). - Financing activities.	100%	-
Red Eléctrica Sistemas de Telecomunicaciones, S.A.U. (RESTEL) - Paseo Conde de los Gaitanes, 177. Alcobendas. Madrid. (Spain). - Acquisition, holding, management and administration of Spanish and foreign equity securities.	100%	-
Red Eléctrica y de Telecomunicaciones, Innovación y Tecnología, S.A.U. (RETIT) - Paseo Conde de los Gaitanes, 177. Alcobendas. Madrid. (Spain). - Activities geared towards driving and accelerating technological innovation.	100%	-
Redcor Reaseguros, S.A (REDCOR) - 26, Rue Louvigny. (Luxembourg). - Reinsurance activities. - Incorporated in 2010 in Luxembourg in order to reinsure the risks of the Group companies, thereby guaranteeing better access to international reinsurance markets.	100%	-
Red Eléctrica Andina, S.A.C. (REA) -Av. Javier Prado Este Of. 1001 Urb. Jardín San Isidro. Lima (Peru) - Rendering of line and substation maintenance services.	-	100%(a)
Red Eléctrica del Sur, S.A. (REDESUR) -Av. Javier Prado Este Of. 1001 Urb. Jardín San Isidro. Lima (Peru) - Electricity transmission and operation and maintenance of electricity transmission networks.	-	100%(a)
Transmisora Eléctrica del Sur, S.A.C. (TESUR) -Av. Javier Prado Este Of. 1001 Urb. Jardín San Isidro. Lima (Peru) - Electricity transmission and operation and maintenance of electricity transmission networks.	-	100%(c)



	2020	
	Percentage ownership (1)	
	Direct	Indirect
Transmisora Eléctrica del Sur 2 , S.A.C. (TESUR 2) -Av. Javier Prado Este Of. 1001 Urb. Jardín San Isidro. Lima (Peru) - Electricity transmission and operation and maintenance of electricity transmission networks.	-	100%(c)
Transmisora Eléctrica del Sur 3 , S.A.C. (TESUR 3) -Av. Javier Prado Este Of. 1001 Urb. Jardín San Isidro. Lima (Peru) - Electricity transmission and operation and maintenance of electricity transmission networks.	-	100%(c)
Transmisora Eléctrica del Sur 4 , S.A.C. (TESUR 4) -Av. Javier Prado Este Of. 1001 Urb. Jardín San Isidro. Lima (Peru) - Electricity transmission and operation and maintenance of electricity transmission networks.	-	100%(j)
Red Eléctrica del Norte Perú, S.A.C. (REDELNOR) -Av. Javier Prado Este Of. 1001 Urb. Jardín San Isidro. Lima (Peru) - Electricity transmission and operation and maintenance of electricity transmission networks.	-	100%(a)
Concesionaria Línea de Transmisión CCNCM, S.A.C. (CCNCM) -Av. Javier Prado Este Of. 1001 Urb. Jardín San Isidro. Lima (Peru) - Electricity transmission and operation and maintenance of electricity transmission networks.	-	100%(d)
Red Eléctrica Chile S.P.A. (RECH) - Avenida El Golf nº 40, piso 20. Comuna de Las Condes, Santiago (Chile) - Acquisition, holding, management and administration of securities.	-	100%(a)
Red Eléctrica del Norte S.A. (REDENOR) - Avenida El Golf nº 40, piso 20. Comuna de Las Condes, Santiago (Chile) - Electricity transmission and operation and maintenance of electricity transmission networks.	-	69.9%(e)
Red Eléctrica del Norte 2 S.A. (REDENOR 2) - Avenida El Golf nº 40, piso 20. Comuna de Las Condes, Santiago (Chile) - Electricity transmission and operation and maintenance of electricity transmission networks.	-	100%(e)
Red Eléctrica Brasil Holding Ltda. -Calle Libero Badaró, 293, 21º andar, conjunto 21-C, sala 11, Centro - Acquisition, holding, management and administration of securities.		100%(a)
Hispatat S.A. - Paseo de la Castellana 39, 28046 Madrid (Spain). - Parent of the Hispatat Group. Operation of the satellite communications system and rendering of space segment services for the geostationary orbital slots allocated to the Spanish state.	-	89.68%(f)(2)
Hispatat Canarias, S.L.U. -Calle Practicante Ignacio Rodriguez s/n Edificio Polivalente IV, Fundación Canarias Parque Científico Tecnológico ULGPC, Planta 3, oficinas 304-305, 35017 Las Palmas de Gran Canaria (Spain) - Sale and lease of satellites and spatial capacity	-	89.68%(g)(2)
Hispatat Brasil, Ltda. - Praia do Flamengo, 200 Rio de Janeiro, (Brazil) - Commercialisation of satellite capacity	-	89.68%(g)(2)
Hispamar Satélites, S.A. - Praia do Flamengo, 200 Rio de Janeiro, (Brazil) - Commercialisation of satellite capacity	-	72.60% (h) (2)
Hispamar Exterior, S.L.U. - Paseo de la Castellana 39, 28046 Madrid (Spain). - Commercialisation of satellite capacity	-	72.60%(i)(2)
Hispatat de México, S.A. de C.V. - Agustín Manuel Chávez 1-001 Col. Centro de Ciudad Santa Fe, 01210 México D.F. (Mexico) - Use of radio spectrum, telecommunications networks and satellite communication.	-	89.68%(g)(2)

- Company  
- Registered office

2020



## - Principal activity

	Percentage ownership (1)	
	Direct	Indirect
Consultek, Inc - 1036 Country Club Drive, Suite 202, Moraga, CA 94556. (United States of America) - Technical consultancy services	-	89.68%(g)(2)
Hispamar Satélites, S.A. (Venezuela) - Torre Phelps, piso 10 ofic. 10, Caracas (Venezuela) - Commercialisation and rendering of satellite telecommunications services	-	72.60%(i)(2)
Hispasat UK, LTD. - 3-7 Temple Avenue, Suite 38, Temple Chambers, London, EC4Y 0HP (England) - Commercialisation and rendering of satellite telecommunications services	-	89.68%(g)(2)
<b>B) Proportionately consolidated companies</b>		
Interconexión Eléctrica Francia-España, S.A.S. (INELFE) - Inmueble Window, 7 C Place du Dôme, 92073 La Défense Cedex, Paris (France) - Study and execution of Spain-France interconnections	-	50%(b)
<b>C) Equity-accounted investees</b>		
Transmisora Eléctrica del Norte S.A. (TEN) - Avenida Apoquindo N°3721, piso 6, Las Condes, Santiago (Chile) - Electricity transmission and operation and maintenance of electricity transmission networks.	-	50%(e)
Hisdesat Servicios Estratégicos, S.A. - Paseo de la Castellana 39, 28046 Madrid (Spain) - Commercialisation of spatial systems for government use.	-	38.56%(g)(2)
Grupo de Navegación Sistemas y Servicios, S.L. - Calle Isaac Newton 1, Madrid (Spain) - Operation of satellite systems	-	12.82%(g)(2)
Argo Energía Emprendimientos y Participaciones S.A. - Calle Tabapuã, 841 - 5º andar - Itaim Bibi - São Paulo/SP (Brazil) - Acquisition, holding, management and administration of securities.	-	50% (k)
Argo Transmisión de Energía S.A. ("Argo I") - Calle Tabapuã, 841 - 5º andar - Itaim Bibi - São Paulo/SP (Brazil) - Electricity transmission and operation and maintenance of electricity transmission networks.	-	50% (l)
Argo II Transmisión de Energía S.A. ("Argo II") - Calle Tabapuã, 841 - 5º andar - Itaim Bibi - São Paulo/SP (Brazil) - Electricity transmission and operation and maintenance of electricity transmission networks.	-	50% (l)
Argo III Transmisión de Energía S.A. ("Argo III") - Calle Tabapuã, 841 - 5º andar - Itaim Bibi - São Paulo/SP (Brazil) - Electricity transmission and operation and maintenance of electricity transmission networks.	-	50% (l)

(1) Equivalent to voting rights.

(2) Company forming part of the Hispasat subgroup.

(a) Investment through Red Eléctrica Internacional, S.A.U.

(b) Investment through Red Eléctrica de España, S.A.U.

(c) Investment through Red Eléctrica del Sur, S.A.

(d) Investment through Red Eléctrica del Norte Perú, S.A.C.

(e) Investment through Red Eléctrica Chile SpA.

(f) Investment through Red Eléctrica Sistemas de Telecomunicaciones, S.A.U.

(g) Investment through Hispasat, S.A.

(h) Investment through Hispasat, S.A. and Hispasat Brasil, Ltda.

(i) Investment through Hispamar Satélites, S.A.

(j) Investment through Red Eléctrica del Sur, S.A. and Red Eléctrica Internacional, S.A.U.

(k) Investment through Red Eléctrica Brasil Holding Ltda.

(l) Investment through Argo Energía Emprendimientos y Participaciones S.A.



**RED**  
**ELÉCTRICA**  
CORPORACIÓN



## **Consolidated Interim Directors' Report for the six-month period ended 30 June 2020**

(Free translation from the original in Spanish. In the event of discrepancy, the Spanish-language version prevails.)





(Free translation from the original in Spanish. In the event of discrepancy, the Spanish-language version prevails.)

## Contents

Contents .....	1
1. Relevant events occurring during the six-month period and outlook .....	2
2. Business performance .....	6
3. Main risks and uncertainties in the second half of the year .....	7
4. Events after 30 June 2020 .....	9

In order to facilitate comprehension of the information provided in this document, certain alternative performance measures have been included. The definition of these measures can be found at [www.ree.es](http://www.ree.es).

The various sections of this consolidated directors' report contain certain prospective information that reflects projections and estimates based on underlying assumptions, statements referring to plans, objectives and expectations associated with future transactions, investments, synergies, products and services, as well as statements concerning results or future dividends, or estimates calculated by the directors and based on assumptions that those directors consider reasonable.

While the Group considers the expectations reflected in those statements to be reasonable, investors and holders of shares in the Parent are advised that the information and statements containing future projections are subject to risks and uncertainties, many of which are difficult to foresee and generally beyond the Group's control. As a result of such risks, actual results and developments could differ substantially from those expressed, implied or forecast in the information and statements containing future projections.

The affirmations and statements containing future projections do not provide any guarantee as to future results and have not been reviewed by auditors outside the Group or by other independent third parties. It is recommended that no decisions be made on the basis of the affirmations and statements containing future projections that refer exclusively to the information available at the date of this report. All of the affirmations and statements containing future projections that are reflected in this report are expressly subject to the warnings given. The affirmations and statements containing future projections included in this document are based on the information available at the date of this directors' report. Except as required by applicable legislation, the Group is not obligated to publicly update its statements or review the information containing future projections, even where new data is published or new events arise.



(Free translation from the original in Spanish. In the event of discrepancy, the Spanish-language version prevails.)

## 1. Relevant events occurring during the six-month period and outlook

---

Red Eléctrica Corporación, S.A. (hereinafter the Parent or the Company) is the Parent of a Group formed by subsidiaries. The Group is also involved in joint operations along with other operators. The Parent and its subsidiaries form the Red Eléctrica Group (hereinafter the Group or Red Eléctrica Group).

The Group's principal activities are the management and operation of electricity infrastructure in Spain, through Red Eléctrica de España S.A.U. (hereinafter REE), and abroad, through Red Eléctrica Internacional S.A.U. (hereinafter REI) and its investees. The Group also provides fibre optic telecommunications services to third parties in Spain through Red Eléctrica Infraestructuras de Telecomunicación, S.A.U. (hereinafter REINTEL), and satellite telecommunications services through the HISPASAT group.

The Group has drawn up a note on the main impacts of COVID-19 on the Group's different activities and financial-economic indicators, which is included in the notes to the condensed consolidated interim financial statements at 30 June 2020.

Regarding the outlook for the different activities conducted by the Group, given that most of the sectors in which the greatest volume of operations in Spain and Latin America is concentrated are regulated sectors, with limited exposure to demand risk, the impact on overall revenue for 2020 is not expected to be significant, despite uncertainties that have not yet dissipated.

As regards investments underway in Spain, the pace is expected to pick up over the coming months, enabling part of the deviation accumulated at 30 June to be offset in the second half of the year. Nonetheless, at the end of this year investments could fall short of the forecast amount, although this deviation should be redressed in 2021. Different projects are underway in Latin America that have been affected by restrictions on freedom of movement and by delays in the supply chain, although the majority of the time lost is expected to be made up over the remainder of the year.

However, depending on future developments in economic recovery in the different sectors and countries in which the Group operates, and the impact of such trends on its activities, certain scenarios could emerge that may require impairment to be recognised.

The Group's management and directors will continue to assess the situation and closely monitor any incidents arising in the essential infrastructure it manages, as well as trends in other external factors and the impact such factors could have on the financial statements.

### **Management and operation of domestic electricity infrastructure**

The investments carried out by the Red Eléctrica Group in Spain up to June 2020 amounted to Euros 169.2 million, of which Euros 130.5 million was used to develop the national transmission network.

The mission of REE, as transmission agent and system operator for the Spanish electricity system, is that of ensuring that the Spanish electricity system functions correctly and guaranteeing the continuity and security of the electricity supply at all times. To this end, it oversees and coordinates the high-voltage electricity system and manages the development of the transmission network. The Company seeks to fulfil its mission while adhering to the principles of neutrality, transparency, independence and economic efficiency, so as to offer a secure, efficient and high quality electricity service to society as a whole.

During the first half of 2020 the transmission network was further shored up by bringing facilities into service that efficiently contribute to the decarbonisation of the economy and to the energy transition. The facilities that entered into service during the first half of 2020 notably include the second Mallorca-Menorca submarine transmission line, a 132 kV line spanning 54.9 km.



(Free translation from the original in Spanish. In the event of discrepancy, the Spanish-language version prevails.)

- **Mainland electricity system**

The most notable events in the first half of 2020 were as follows:

Mainland energy demand amounted to 113,865 GWh, down 7.8% on the first half of 2019. Adjusted for calendar and temperature effects, the decline was also 7.8%. This drop stems from the state of emergency declared to address the COVID-19 situation.

Demand for hourly average power and daily electricity peaked on 20 and 21 January at 39,990 MW and 820 GWh, respectively, down 0.4% and 0.5% on the maximum levels recorded in the first half of 2019.

Notably, 47.8% of demand was covered with renewable power generation, which is 7.8 percentage points up on the same period in 2019.

Maximum instantaneous power and daily electricity from wind power were recorded on 1 March, at 17,378 MW and 356 GWh respectively, up 2.8% and down 4.3%, respectively, on the maximum levels recorded in the first half of 2019.

As in the prior year, international electricity exchanges resulted in a net import balance, amounting to 4,197 GWh in the first half of 2020, 16.5% less than in the same period in 2019.

The performance of REE's mainland transmission network has once again been excellent, with provisional total availability of the network to June at 98.95%, above the 98.27% achieved in the same period of the prior year. The continuity of supply indicators were below the thresholds set out in Royal Decree 1955/2000, with an accumulated ENS (energy not supplied) and AIT (average interruption time) to June 2020 of 16.10 MWh and 0.037 minutes, respectively (21.41 MWh and 0.045 minutes at June 2019), highlighting the continuing high degree of security and quality provided by Red Eléctrica facilities.

- **Non-mainland electricity systems**

Within the Balearic Islands system, demand to June 2020 was down 18.6% on the same period of the prior year. Temperatures have had a negative impact of 0.8% on demand.

The electricity link-up to the mainland (Morvedre-Santa-Ponsa) has continued to contribute to the security and quality of supply. Electricity from the mainland covered 27.2% of the demand in this system (28.9% in 2019).

Demand in the Canary Island system was down 10.1% in the first half of 2020 compared to the same period of the prior year. Moreover, accumulated renewable power generation (wind, photovoltaic, other renewables and wind-hydro power) accounted for 16.1% of total output in the first half of 2020 (13.8% in 2019).

### **Management and operation of international electricity infrastructure**

The Group's international business is conducted through its subsidiary Red Eléctrica Internacional (REI). The start-up of operations in Peru, Chile and, more recently, in Brazil is the outcome of an ongoing analysis of business opportunities, and meets the Group's criterion of undertaking investments in countries with a favourable economic situation and a stable regulatory framework that ensures an appropriate return on the investments.

The COVID-19 crisis has not had a particularly significant impact on activity in these three countries, as business operations have been adapted to ensure the continuity of the services provided.

In Latin America – specifically Chile, Peru and Brazil – the fall in electricity demand was 30% in Peru and more than 10% in Brazil, while in Chile the decline in demand was not significant, inasmuch as mining activity was not halted due to the pandemic.



(Free translation from the original in Spanish. In the event of discrepancy, the Spanish-language version prevails.)

Overall, the Group manages a network spanning more than 4,800 km in Peru, Chile and Brazil, of which approximately 4,300 km are up and running at present.

The current corporate structure of the international business is as follows:

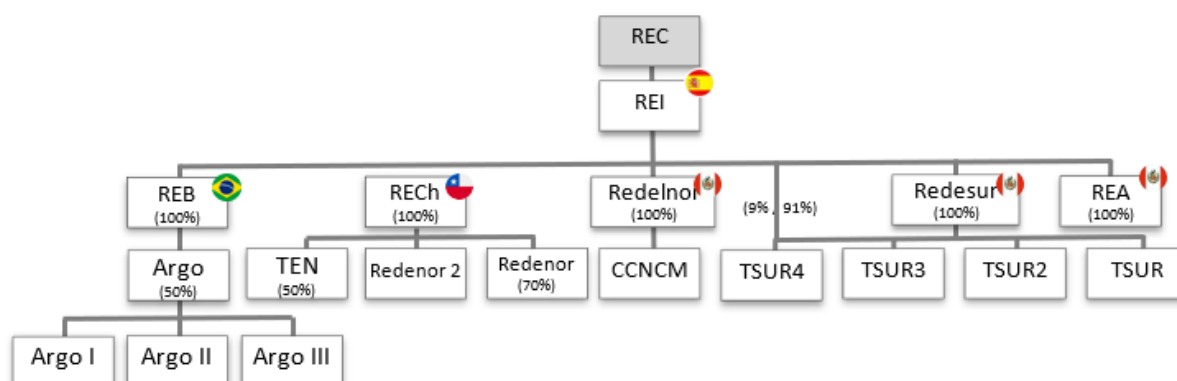

#### • Activities carried out in Peru

The Group is the main transmission agent in the south of Peru. REI directly holds 100% of the capital of the Peruvian companies REA, REDELNOR and REDESUR. In turn, REDESUR holds 100% of TESUR, TESUR 2 and TESUR 3, and 91% of TESUR 4, the remaining 9% of which is held directly by REI.

At present REDESUR, TESUR, TESUR 2 and TESUR 3 are concessions under commercial operation for a period of 30 years, and TESUR 4 is at the construction stage.

In March 2020, the TESUR 3 facilities and the project to extend REDESUR's Puno substation came into service.

As regards the lines under construction, TESUR 4 is in the environmental formalities phase with an overall stage of completion for the project of 44.5%.

During the first half of the year, the average voltage levels remained within the limits set out in the Technical Standard for Quality of Electricity Services, no incidents were recorded in quality of service during the period, and network availability stood at 100% in TESUR, TESUR 2 and TESUR 3, 99.99% in CCNCM and 99.998% in REDESUR.

#### • Activities carried out in Chile

In Chile, the Group acquired a 50% interest in TEN in 2016. This company is responsible for the construction and maintenance of the Mejillones-Cardones line, which was brought into service in November 2017. This project constitutes the first connection between the Far North Interconnection System ("SING") and the Central Interconnected System ("SIC"), enabling the evacuation of renewable energy from the north of the country and the creation of a single energy market in Chile.

During the first half of 2020, TEN maintained a high availability rate among its facilities (99.58% for lines and 99.91% for substations).

REDENOR is engaged in the design, construction and subsequent operation and maintenance of a substation and three lines in the Far North Interconnection System close to the border with Peru, which are currently at the construction stage.



(Free translation from the original in Spanish. In the event of discrepancy, the Spanish-language version prevails.)

REDENOR 2 is engaged in the commercial operation of its facilities (three 220 kV / 265 km lines linking the El Cobre – Esperanza – El Tesoro – Encuentro substations). During the first half of 2020, it maintained a high availability rate among its facilities (99.85%). It is also immersed in the extension works on its facilities encompassed in the Transmission System Expansion Plan, entailing the construction of a new 220 kV substation (SE Centinela).

- **Activities carried out in Brazil**

In Brazil, on 25 March 2020 the Group acquired a 50% interest in the Brazilian holding company Argo Energía, which in turn holds the Argo I, Argo II and Argo III concessions. This acquisition was made through the Group's main company in that country Red Eléctrica Brasil (REB), which was incorporated by REI in January 2020.

The primary concession, Argo I, makes up 80% of Argo's revenue and has been operating since the end of 2019, running 1,110 km of 500kV lines and five substations in the Northeast Region of Brazil.

Argo II is a project to expand a substation that is currently under construction in the state of Minas Gerais.

Argo III comprises the construction of 320 km of 230kV lines (of which 165 km have been operating since the end of May 2020, with a cumulative availability rate of 100% at June) and the expansion of five substations in the state of Rondônia.

## Telecommunications

- **Satellite business**

This activity is conducted through HISPASAT, in which the Group holds an 89.68% interest through Red Eléctrica Sistemas de Telecomunicaciones S.A. (RETEL).

Hispasat is the leading satellite infrastructure operator in Spain and Portugal by volume of business, and also ranks as the fourth operator in Latin America and the ninth operator worldwide. It is a leading distributor of Spanish and Portuguese content and has a substantial presence in the Americas and EMEA, mainly covering the Iberian Peninsula. It owns a fleet of nine satellites in orbit that are monitored from the control centres in Brazil and Spain.

The Hispasat Group's principal activity consists of leasing spatial capacity and providing broadband managed services, through the operation and commercial exploitation of its fleet of satellites in orbit and the related land-based segment. These activities are conducted through the Group's parent, Hispasat, S.A., which operates and commercialises the Group's satellites that are not located in orbit over Brazilian territory, and through Hispasat Canarias, S.L., Sociedad Unipersonal, Hispamar Satélites, S.A., Hispamar Exterior, S.L., Sociedad Unipersonal, and Hispasat México, S.A. de C.V., which jointly operate and commercialise the satellites that are in orbit over Brazilian territory.

The Group has a corporate presence in five countries: Spain, Brazil, Mexico, Argentina and Colombia, and serves customers in more than 26 countries.

In the first half of 2020 work remained ongoing on the design and manufacture of the new Amazonas Nexus satellite, which comes with a new generation HTS payload and a digital processor.

In addition, in this first half of the year satellite activity revenue from services provided in both Europe and Latin America fell short of forecast sales due to the COVID-19 situation.

- **Fibre optics business**

The fibre optic telecommunications activities conducted by the Red Eléctrica Group are centred on the commercial operation of the surplus capacity of the fibre optic networks and infrastructure associated



(Free translation from the original in Spanish. In the event of discrepancy, the Spanish-language version prevails.)

with the electricity transmission network and the railway network owned by Adif-Alta Velocidad, to which the Group holds the rights of use and exploitation. This activity is carried out through the Group's wholly-owned subsidiary REINTEL.

REINTEL is the largest neutral operator of dark fibre infrastructure in Spain. Its principal activity is the lease of dark fibre and sites. REINTEL has a fibre optic network in excess of 50,600 km rolled out over the electricity transmission network and the railway network and its main customers are telecommunications operators present in Spain. REINTEL also provides maintenance services for fibre optic cables and telecommunications equipment.

Throughout the first half of 2020, REINTEL continued to implement its commercial plan as a telecommunications infrastructure supplier, expanding its customer portfolio and undertaking investments where requested by customers, thereby generating greater revenues for the Group.

Activity in recent months has been marked by the response to the COVID-19 crisis, with the adaptation of business operations aimed at ensuring continuity in the provision of essential telecommunications services for both the Red Eléctrica Group and customers of REINTEL.

Incidents on the fibre optic network have been addressed within the timescales established with customers. At the end of June, no past-due balances for significant amounts have been recognised.

Commercial activity in this first half of 2020 has been sustained, and therefore no negative impact is expected on defaults or the key financial-economic indicators in 2020.

## 2. Business performance

---

Revenue for the first six months of 2020 totals Euros 977.9 million. Highlights include the positive performance of the system operation activity, the inclusion of Hispasat for the first time in this six-month period, with revenue of Euros 79.2 million, the good pace of activity relating to the marketing of fibre optics and the international business, which reflects a full quarter for the Brazilian company Argo. Only electricity transmission has displayed negative performance year-on-year, and this is due to the application of the new remuneration parameters, impacting on the transmission activity in Spain as of 1 January and bringing about a 1.5% drop in revenue compared to the first half of 2019.

EBITDA amounted to Euros 766.2 million, down 1.7% on the same period of the prior year. EBITDA includes the Euros 8.0 million contribution to profit from the equity-accounted investees TEN, Argo and Hisdesat.

Operating expenses were as follows:

- The cost of supplies and other operating expenses fell 2.3% compared with the first half of the prior year, despite the inclusion of Euros 13.4 million from Hispasat. The performance of this item emphasises the Red Eléctrica Group's significant cost-cutting efforts.
- The headcount was 2,031 at 30 June, while the average workforce was 2,052 employees.

Personnel expenses rose 13.6% on the prior period. This increase is essentially due to 14% growth in the average workforce as a result of Hispasat's incorporation into the Group. This item also includes expenses associated with the voluntary redundancy plan rolled out at the beginning of the year.

EBIT totalled Euros 509.3 million, down 6.5% year-on-year. This trend is mainly due to higher depreciation and amortisation charges following Hispasat's inclusion in the consolidated Group, which has entailed a Euros 59.7 million increase in this charge.

The net finance cost amounts to Euros 69.5 million, which is a 9.0% higher cost than for the first six months of 2019. This is due to the rise in average net financial debt from Euros 5,778.8 million at 30 June 2019 to Euros 6,918.5 million one year later.



(Free translation from the original in Spanish. In the event of discrepancy, the Spanish-language version prevails.)

Lastly, profit for the first six months of the year totalled Euros 331.7 million, sliding 8.4% compared to the same period of the previous year. The tax rate stood at 24.6%.

### 3. Main risks and uncertainties in the second half of the year

---

The Red Eléctrica Group is exposed to the different risks inherent in the activities and geographical markets in which it operates, which could have an impact on its results.

The Group's risk management system works on a comprehensive and ongoing basis, and risk management is further consolidated at corporate level by business unit, subsidiary and support area. This Comprehensive Risk Management System aims to ensure that any risks, including those relating to tax, that might affect the Group's strategies and objectives are systematically identified, analysed, assessed, managed and controlled, according to uniform criteria and within the established risk levels, in order to facilitate compliance with the strategies and objectives of the Group. The Group's comprehensive risk management policy and general comprehensive risk management and control procedures are based on the COSO II (Committee of Sponsoring Organizations of the Treadway Commission) Enterprise Risk Management Integrated Framework.

This process of risk identification, analysis, assessment and control sets out the actions required to reduce risk to an acceptable level. For risk monitoring purposes, the existing risk management system contains numerous management plans to mitigate these risks and a large number of indicators to monitor changes therein. The Internal Audit and Risk Control Department reviews the progress and impact of the previously established risk management plans in conjunction with the organisational units on a half-yearly basis for high-level and other significant risks, annually for other risks, and whenever circumstances so advise in the case of specific risks. The Audit Committee supervises this process at least twice a year and reports thereon to the board of directors.

Moreover, the Group's processes have been designed so as to incorporate elements to mitigate or reduce the associated risks. These processes have been integrated within the management systems established under international standards (including ISO 9001, ISO 14001 and ISO 45001), which are subject to systematic internal and external audits on the suitability of design and compliance, and incorporate the control aspects specific to the objectives to be met.

The Group has also drawn up contingency plans to manage the various crisis situations that could arise in the event of an electrical incident (in terms of guaranteeing security of supply) or non-electrical incident that could affect the environment, people, business operations, system availability, business results or any other event that could impact the Company's reputation. Along these lines, the response to the exceptional scenario arising from the COVID-19 pandemic should be highlighted. In accordance with the Group's Business Continuity Plan, the pertinent response protocol was activated, firstly to ensure the safety of the Group's employees, and secondly to guarantee the continuity of the Company's activity and the correct discharge of its main duties. In parallel, the Internal Audit and Risk Control Area, alongside the other areas, reviewed the possible impact of this situation on the Group's relevant risks, noting on the whole that the risk assessments had not changed significantly. However, developments in external factors and the possible medium-term impact will need to be continually monitored.

The Group also has guidelines for managing cyber incidents, which sets out the criteria and guidelines for managing any cyber security incident, irrespective of the area concerned.

In addition, the Group has an Internal Control over Financial Reporting (ICQFR) system, so as to ensure efficiency and security in the preparation of its economic and financial information, for which it has adopted international best practices.





(Free translation from the original in Spanish. In the event of discrepancy, the Spanish-language version prevails.)

The main risks to which the Red Eléctrica Group is exposed and that could affect achievement of its objectives are regulatory risk, inasmuch as the Group's principal business lines are subject to regulations, operational risk, primarily relating to electricity system servicing activities, and financial risk.

### Regulatory risks

The fact that the activities are regulated affects revenue and the conditions under which the principal activities must be carried out. In this respect, regulatory risks could arise from the possibility of changes to the legal framework applicable to the activities in the different geographical areas in which the Group carries out its activities, which could affect both revenue and costs, either directly or because new requirements are introduced.

### Operational risks

The Group's activities are exposed to different operational risks, such as faults in the electricity transmission network, the fibre optic network or satellite infrastructure, fires at facilities, adverse meteorological conditions, accidents within the transmission network, incidents that could affect physical/logical security, as well as other events that could result in damage to the Group's facilities or harm to people and/or materials. To this end, the Group has established control systems that have worked satisfactorily in the past in resolving such events.

Furthermore, the Group has arranged corporate insurance policies to shield its equity and limit the potential impact of such events on its results.

### Financial risks

The Group is exposed to volatility in interest and exchange rates, which could affect its financial position.

In terms of exchange rate fluctuations, any adverse changes in exchange rates that could affect the Group's forecast results are considered.

Currency risk management considers transaction risk, arising on cash inflows and outflows in currencies other than the Euro, and translation risk, i.e. the Group's exposure when consolidating its subsidiaries and/or assets located in countries whose functional currency is not the Euro. With a view to reducing the currency risk on issues in the US private placements (USPP) market, the Group has arranged cash flow hedges through US Dollar/Euro cross-currency swaps on the principal and interest, which cover the amount and total term of the issue up to October 2035. Forward cash flow hedges have also been arranged, to hedge highly probable cash flows relating to certain income and/or payment commitments in Brazilian Reals and US Dollars. In order to mitigate the translation risk on assets located in countries whose functional currency is not the Euro, the Group finances a portion of its investments in the functional currency of those countries. The Group has also arranged hedges of net investments in US Dollars using cross-currency swaps up to January 2021.

At 30 June 2020, the Group has a low-risk debt structure with moderate exposure to fluctuations in interest rates. As a result of the debt policy implemented, which aims to bring the cost of debt into line with the financial rate of return applied to the Group's regulated assets, among other objectives, 83% of the Group's borrowings have been arranged at fixed rates. The interest rate risk to which the Group is exposed derives from changes in the fair value of derivative financial instruments and mostly affects equity, but not profit for the period. The benchmark interest rate reform is not expected to have a significant impact on the Group's financial statements.



(Free translation from the original in Spanish. In the event of discrepancy, the Spanish-language version prevails.)

#### **4. Events after 30 June 2020**

---

No significant events have occurred between the reporting date and the date on which these consolidated interim financial statements were authorised for issue.