

to get all water out jack up front and side of T&G.
 use pump to get what is left after using drain
 should be able get to all but a pint or so out
 have done this to 3 t&gs worked each
 time

COST = \$20

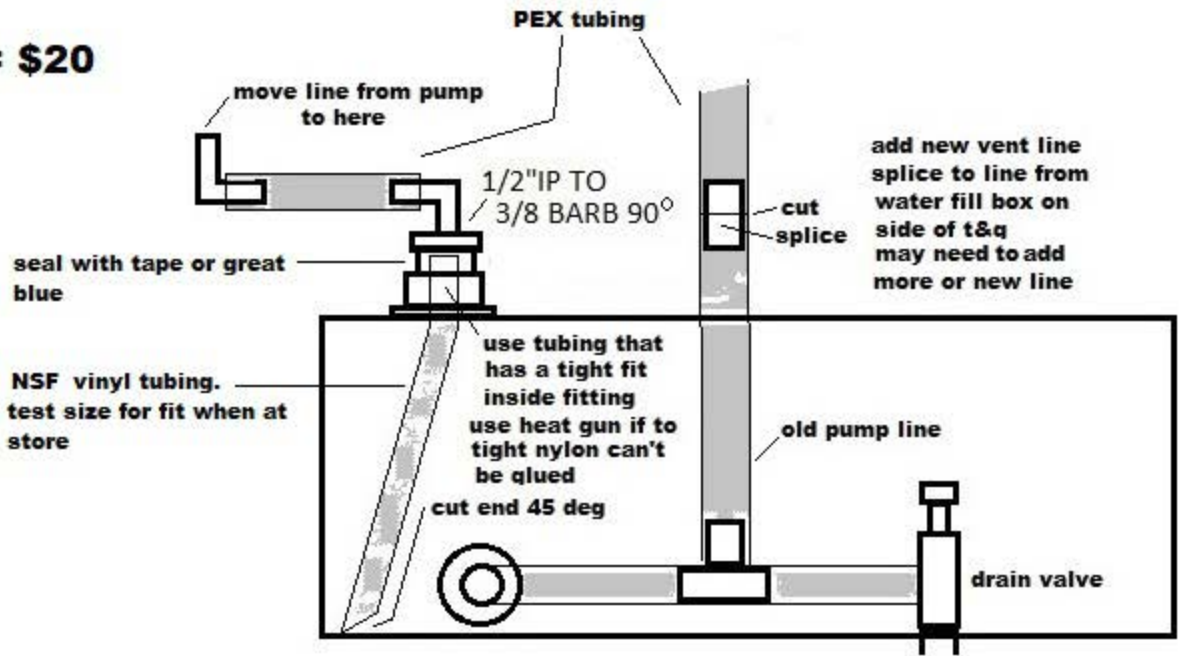

about 3 FT of 3/8" PEX line and 5
 hose clampd
 remember to use hose clamps

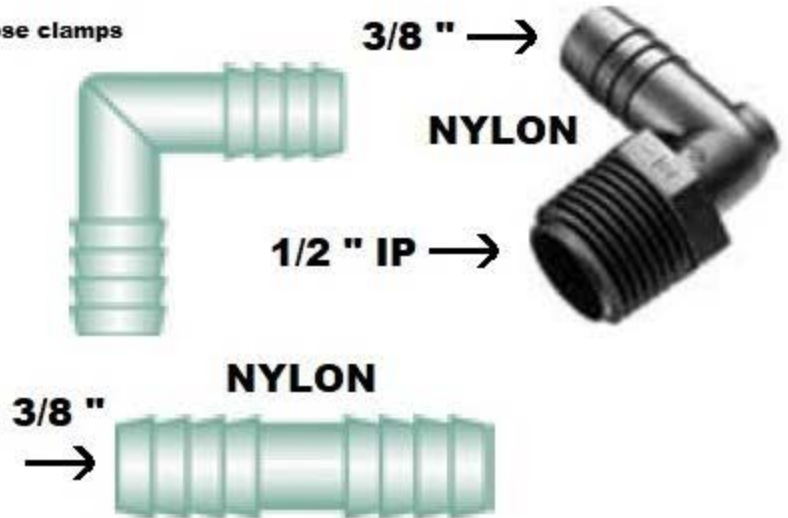
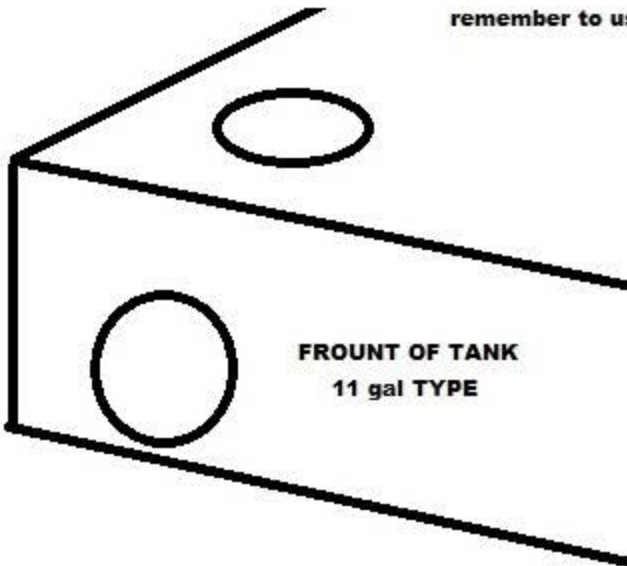

FRONT OF TANK
 11 gal TYPE